

INSTALLATION MANUAL

STANDARD ECM MODULAR MULTI-POSITION AIR HANDLERS MODELS: ME SERIES



LIST OF SECTIONS

GENERAL	1	UNIT DATA	8
SAFETY	1	MAINTENANCE	14
UNIT INSTALLATION	2	AIR SYSTEM ADJUSTMENT	14
DUCT WORK AND CONNECTIONS	5	TYPICAL THERMOSTAT CONNECTIONS	14
ELECTRIC HEATER INSTALLATION	6	WIRING DIAGRAM	15
LINE POWER CONNECTIONS	6	TYPICAL THERMOSTAT CONNECTIONS	17
LOW VOLTAGE CONTROL CONNECTIONS	7	START UP SHEET	19
BLOWER SPEED CONNECTIONS	7		

LIST OF FIGURES

Return Air Duct Attachment	2	Duct Work Transition	7
Typical Installation	4	Line Power Connections	8
Coil and Air Handler Attachment Details	4	Blower Speed Connections	8
Gasket Location	5	Typical Thermostat Wiring Diagram - ECM	16
Dimensions & Duct Connection Dimensions	5	Wiring Diagram - Standard ECM - Single Phase Heat Kits	17
Typical Horizontal Installation	6	Wiring Diagram - Three Phase Heat Kits	18
Duct Attachment	6	Typical Thermostat Wiring Diagram - 2 Stage Heat Pump with ECM Blower Motor	19

LIST OF TABLES

Dimensions	4	Electrical Data For Single Source Power Supply: 208/230-1-60	9
Physical and Electrical Data - Cooling Only	8	Electrical Data For Multi-source Power Supply: 208/230-1-60	10
Electrical Data - Cooling Only	8	Electrical Data For Single Source Power Supply: 208/230-3-60	11
Electrical Heat: Minimum Fan Speed	8	Electrical Data For Multi-source Power Supply: 208/230-3-60	11
KW & MBH Conversions - For Total Power Input Requirement	8	Air Flow Data (CFM)	12
Electric Heat Performance Data: 208/230-1-60 & 208/230-3-60	9		

SECTION I: GENERAL

The ME modular air handler series provides the flexibility for installation in any position. This unit may be used for upflow, downflow, horizontal right, or horizontal left applications.

These units may be located in a closet, utility room, attic, crawl space, or basement. These versatile models may be used for cooling or heat pump operation with or without electric heat or indoor coil.

Top or side power and control wiring, color coded leads for control wiring, and electric heaters all combine to make the installation easy and minimize installation cost.

Electric heat kits are available as field installed accessories. Single phase kits are available from 2.5 kW to 25 kW. 208-230 volt three phase kits are available from 10kW to 25kW.

SECTION II: SAFETY



This is a safety alert symbol. When you see this symbol on labels or in manuals, be alert to the potential for personal injury.

Understand and pay particular attention to the signal words **DANGER**, **WARNING**, or **CAUTION**.

DANGER indicates an **imminently** hazardous situation, which, if not avoided, **will result in death or serious injury**.

WARNING indicates a **potentially** hazardous situation, which, if not avoided, **could result in death or serious injury**.

CAUTION indicates a potentially hazardous situation, which, if not avoided **may result in minor or moderate injury**. It is also used to alert against unsafe practices and hazards involving only property damage.

WARNING

FIRE OR ELECTRICAL HAZARD

Failure to follow the safety warnings exactly could result in serious injury, death or property damage. A fire or electrical hazard may result causing property damage, personal injury or loss of life.

WARNING

The air handler area must not be used as a broom closet or for any other storage purposes, as a fire hazard may be created. Never store items such as the following on, near or in contact with the furnace.

1. Spray or aerosol cans, rags, brooms, dust mops, vacuum cleaners or other cleaning tools.
2. Soap powders, bleaches, waxes or other Cleaning compounds; plastic items or containers; gasoline, kerosene, cigarette lighter fluid, dry cleaning fluids or other volatile fluid.
3. Paint thinners and other painting compounds.
4. Paper bags, boxes or other paper products

Never operate the air handler with the blower door removed. To do so could result in serious personal injury and/or equipment damage.

WARNING

Improper installation, adjustment, alteration, or maintenance may create a condition where the operation of the product could cause personal injury or property damage. Refer to this manual for assistance, or for additional information, consult a qualified contractor, installer, or service agency.

⚠ CAUTION

This product must be installed in strict compliance with the installation instructions and any applicable local, state, and national codes including, but not limited to building, electrical, and mechanical codes.

SAFETY REQUIREMENTS

1. Failure to carefully read and follow all instructions in this manual can result in air handler malfunction, death, personal injury and/or property damage.
2. This air handler should be installed in accordance with all national and local building/safety codes and requirements, local plumbing or wastewater codes, and other applicable codes.
3. This air handler should be installed only in a location and position specified in the "Unit Installation" section of this Instruction Manual.
4. The air handler is not to be used for temporary heating of buildings or structures under construction.
5. Always install the air handler to operate within the air handler's intended maximum outlet air temperature.
6. The unit rating plate displays the air handler model number. The unit dimensions for the supply air plenum are provided in Figure 5 and Table 1 of this Instruction Manual. The plenum must be installed according to the instructions. The return air duct attachment is shown in Figure 1.
7. Clearance from combustible material is provided under "Clearances" in the "Unit Installation" section.
8. It is necessary to maintain clearances for servicing. Access must be allowed for electric heaters and blower.
9. The unit rating plate and power supply must be verified to ensure that the electrical characteristics match.
10. Air handler shall be installed so the electrical components are protected from water.
11. Installing and servicing heating/cooling equipment can be hazardous due to the electrical components. Only trained and licensed personnel should install, repair, or service heating/cooling equipment. Unlicensed service personnel can perform basic maintenance functions such as cleaning and replacing the air filters. When working on heating/cooling equipment, the precautions in the manuals and on the labels attached to the unit and other safety precautions must be observed as applicable.

⚠ CAUTION

These air handlers should be transported & handled in an upright, upflow position. Failure to do so may result in unit damage and personal injury. Configuration conversions should be done at site of installation.

12. These instructions cover minimum requirements and conform to existing national standards and safety codes. In some instances these instructions exceed certain local codes and ordinances, especially those who have not kept up with changing residential and non-HUD modular home construction practices. These instructions are required as a minimum for a safe installation.

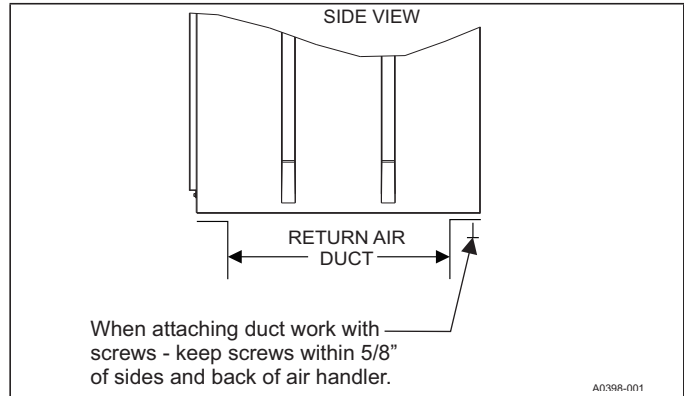

FIGURE 1: Return Air Duct Attachment

INSPECTION

As soon as a unit is received, it should be inspected for possible damage during transit. If damage is evident, the extent of the damage should be noted on the carrier's freight bill. A separate request for inspection by the carrier's agent should be made in writing. Also, before installation the unit should be checked for screws or bolts, which may have loosened in transit. There are no shipping or spacer brackets which need to be removed.

It should be verified that all accessories such as heater kits and coils are available. Installation of these accessories or field conversion of the unit should be accomplished before setting the unit in place or connecting any wiring, duct work or piping.

SECTION III: UNIT INSTALLATION

UNIT SIZING

1. The size of the unit should be based on an acceptable heat loss or gain calculation for the structure. The ACCA – Manual J or other approved methods may be used. Reference Figure 5 and Table 1.
2. Only connect the air handler to a duct system which has an external static pressure within the allowable range.
3. Airflow must be within the minimum and maximum limits approved for electric heat, indoor coils and outdoor units.

Entering Air Temperature Limits			
Wet Bulb Temp. °F		Dry Bulb Temp. °F	
Min.	Max.	Min.	Max.
57	72	65	95

4. When an air handler is installed so that supply ducts carry air circulated by the air handler to areas outside the space containing the air handler, the return air shall also be handled by duct(s) sealed to the air handler casing and terminating in the space to be cooled/heated.
5. Refer to the unit rating plate for the air handler model number, and then see the dimensions page of this instruction for supply air plenum dimensions. The plenum must be installed according to the instructions.
6. The installer must check available supply power and verify that it is within the normal operating voltage range for the unit. The acceptable voltage range for these units is as follows:

Air Handler Voltage	Normal Operating ¹ Voltage Range
208-230-1-60	187-253

1. Rated in accordance with ARI Standard 110, utilization range "A".

CLEARANCES

Clearances must be taken into consideration, and provided for as follows:

1. Maintenance and servicing access - minimum 36" from front of unit recommended for blower motor / coil replacement.
2. The duct work connected to this unit is designed for zero clearance to combustible materials.
3. A combustible floor base accessory is available for downflow applications of this unit, if required by local code.

LOCATION

Location is usually predetermined. Check with owner's or dealer's installation plans. If location has not been decided, consider the following in choosing a suitable location:

1. Select a location with adequate structural support, space for service access, and clearance for air return and supply duct connections.
2. Using hanging brackets to wall mount this single piece air handler unit is not recommended.
3. Normal operating sound levels may be objectionable if the air handler is placed directly over some rooms such as bedrooms, study, etc.
4. If using the air handler unit with an indoor coil, select a location that will permit installation of condensate line to open drain or outdoors allowing condensate to drain away from structure.

NOTICE

The primary and secondary drain line must be trapped to allow proper drainage of condensate water. The secondary drain line should be piped to a location that will give the occupant a visual warning that the primary drain is clogged. If the secondary drain line is not used, it must be capped.

5. When an indoor coil is installed in an attic or above a finished ceiling, an auxiliary drain pan should be provided under the air handler as is specified by most local building codes.
6. Proper electrical supply must be available.
7. If unit is located in an area of high humidity (i.e. an unconditioned garage or attic), nuisance sweating of casing may occur. On these installations, unit duct connections and other openings should be properly sealed, and a wrap of 2" fiberglass insulation with vinyl vapor barrier should be used.

AIR HANDLER CONFIGURATION

These air handler units are supplied ready to be installed in an upflow, downflow, horizontal right or horizontal left position. Refer to Figure 2. The unit requires no conversion procedures.

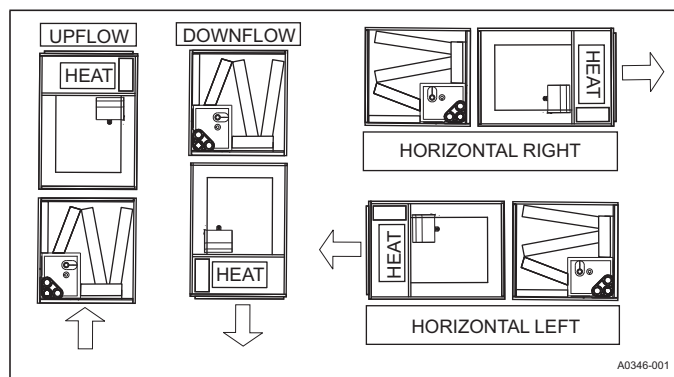

FIGURE 2: Typical Installation

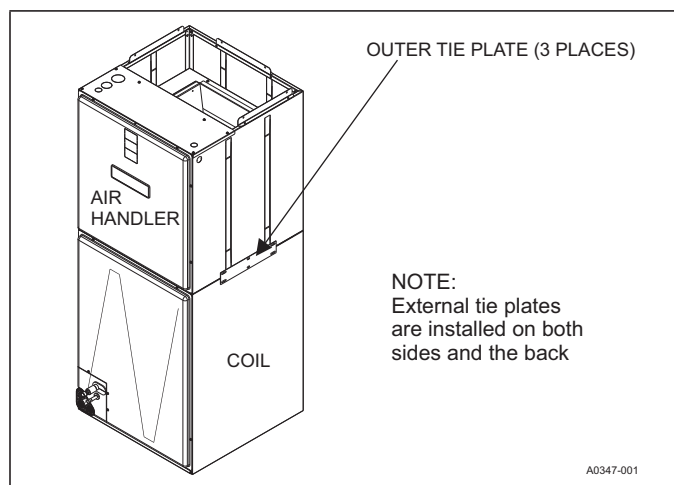

FIGURE 3: Coil and Air Handler Attachment Details

AIR HANDLER AND COIL UPFLOW, DOWNFLOW, AND HORIZONTAL POSITIONS

1. Apply neoprene gasket to the return air end of air handler.
2. Attach three tie plates to external sides and back of air handler casing using screws. Refer to Figure 3.
3. Position blower casing over appropriate coil opening (depending on configuration). Refer to Figure 2.
4. Attach the three tie plates to coil casing using screws. Refer to Figure 3.
5. Remove coil access panel and coil filter door.
6. Slide the coil out of the coil cabinet, and set coil to the side.
7. Locate 2" wide foam gasket.
8. Apply foam gasket over the air handler and coil mating seams on the interior of both unit sides and back. Refer to Figure 4.
9. Slide the coil into the housing, and install the coil access panel and coil filter door.



FIGURE 4: Gasket Location

A0353-001

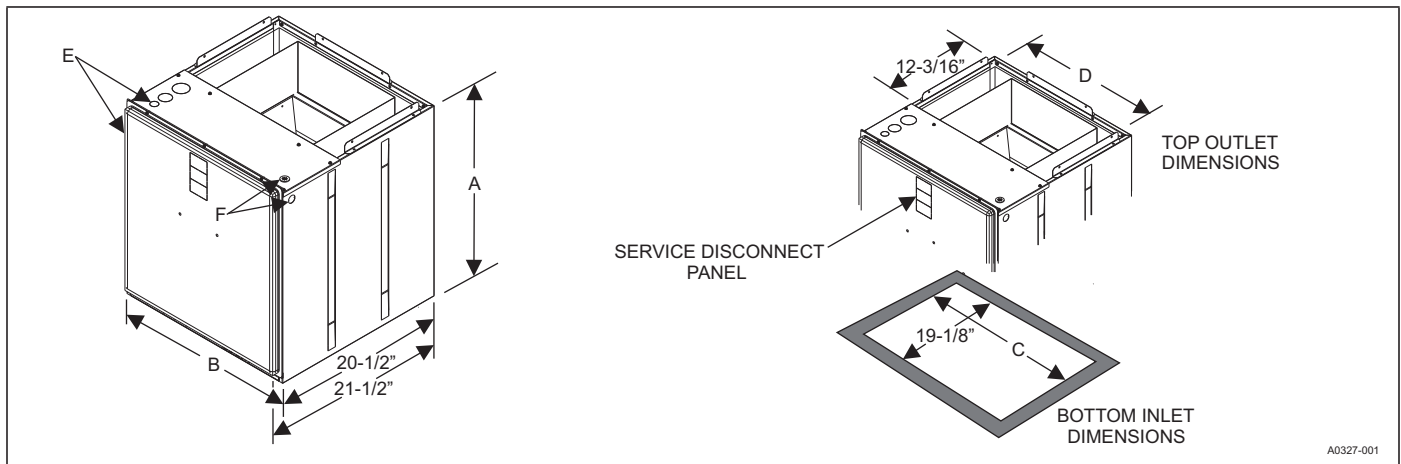

FIGURE 5: Dimensions & Duct Connection Dimensions

A0327-001

TABLE 1: Dimensions

ME MODELS	Dimensions ¹				Wiring Knockout Dimensions ^{1, 2}	
	A	B	C	D	E	F
	Height	Width	Bottom Opening	Top Opening	Power	Control
ME08B	21-1/2	17-1/2	16-1/2	16-1/2	7/8 (1/2) 1-3/8 (1) 1-23/32 (1-1/4)	7/8 (1/2)
ME12B	21-1/2	17-1/2	16-1/2	16-1/2		
ME14D	22-1/2	24-1/2	23-1/2	23-1/2		
ME16C	22-1/2	21	20	20		
ME20D	22-1/2	24-1/2	23-1/2	23-1/2		

1. Dimensions are in inches.
 2. Actual size (Conduit size).

SECTION IV: DUCT WORK AND CONNECTIONS

⚠ WARNING

Use only 1/2" screws to connect duct work to bottom of unit.

Air supply and return may be handled in one of several ways best suited to the installation. Upflow, horizontal or downflow applications may be used.

The vast majority of problems encountered with heating and cooling systems can be linked to improperly designed or installed duct systems. It is therefore highly important to the success of an installation that the duct system be properly designed and installed.

When installing a central air return grille in or near the living space, it is advisable to design the duct work so that the grille is not in direct line with the opening in the unit. One or two elbows and acoustical duct liner assures a quieter system. Operation where return air duct is short or where sound may be a problem, acoustical duct liner should be used inside the duct. Use flexible duct connectors to minimize the transmission of vibration/noise into the conditioned space.

⚠ WARNING

Do not bring in return air from a location which could introduce hazardous substances into the airflow.

Use 1/2" screws to connect duct work to cabinet. If pilot holes are drilled, drill only through field duct and unit flange.

Insulation of duct work is a must where it runs through an unheated space during the heating season or through an uncooled space during the cooling season. The use of a vapor barrier is recommended to prevent absorption of moisture from the surrounding air into the insulation.

The supply air duct should be properly sized by use of a transition to match unit opening. All ducts should be suspended using flexible hangers and never fastened directly to the structure.

⚠ CAUTION

This unit is not designed for non-ducted (freeblow) applications. Do not operate without duct work attached to unit.

Equipment should never be operated without filters.

Duct work should be fabricated and installed in accordance with local and/or national codes. This includes the standards of the National Fire Protection Association for Installation of Air-Conditioning and Ventilating Systems, NFPA No. 90B. If electric heat is used, non-flammable material must be used. Duct systems should be designed in accordance with the Air Conditioning Contractors of America (ACCA) – Manual D.

HORIZONTAL SUSPENSION

For suspension of these units in horizontal applications, it is recommended to use angle steel support brackets with threaded rods, supporting the units from the bottom, at the locations shown in Figure 6.

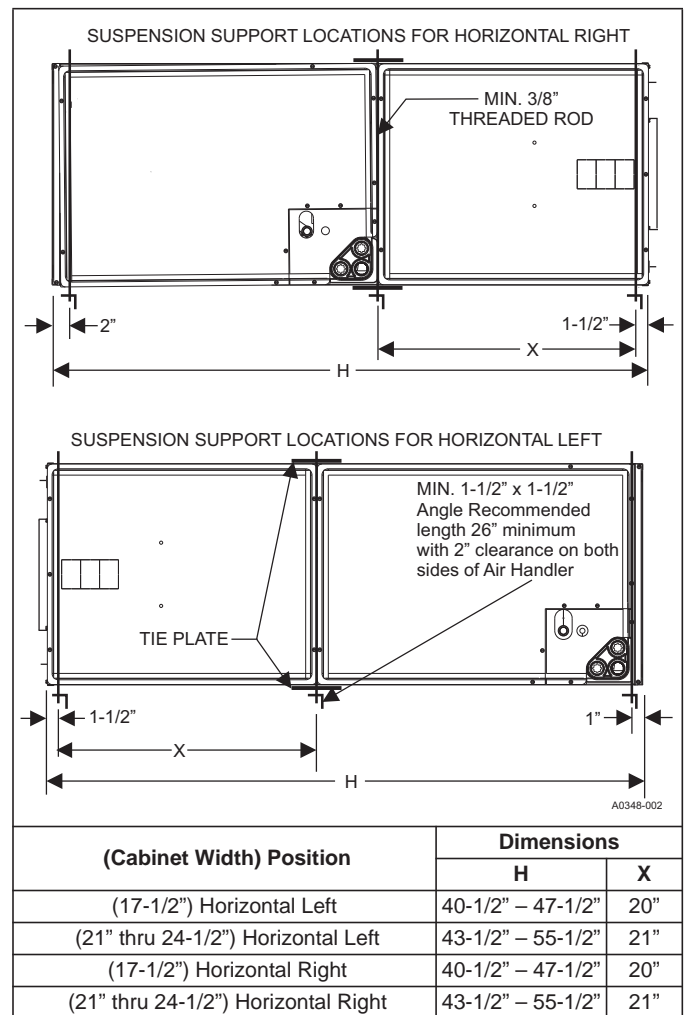

FIGURE 6: Typical Horizontal Installation

DUCT FLANGES

Three duct flanges are provided to assist in positioning and attaching duct work to the air handler. These flanges are included in the unit parts bag. With the screws from the parts bag, install one of the duct flanges. Duct flanges have holes on both legs with one leg longer than the other. The longer leg can be used to mate against the air handler so that different thicknesses of duct board can be made flush with the outer surface of the air handler. Repeat the procedure for the other two flanges. Refer to Figure 7. If the flanges are not used, they may be discarded.

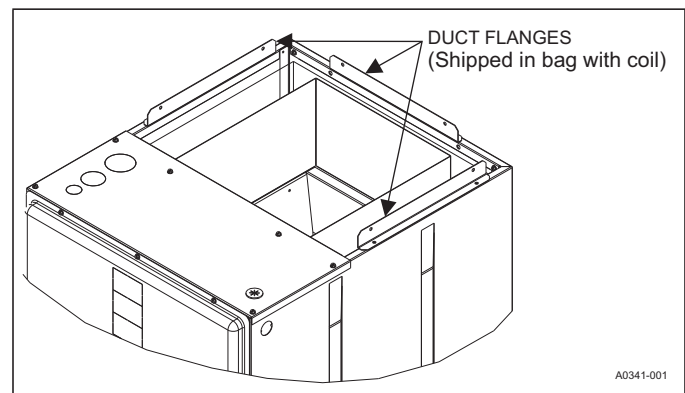

FIGURE 7: Duct Attachment

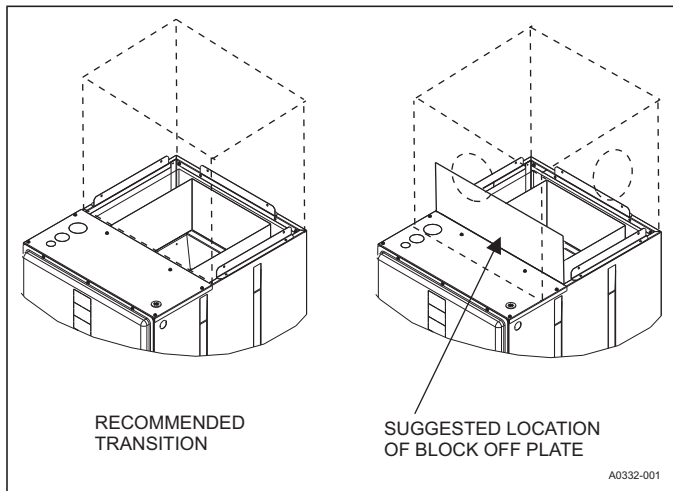

FIGURE 8: Duct Work Transition

UNIT CONNECTIONS

There are several ways to handle the supply and return air duct connections. The location and sizing of the connections depends on the situation and the method best suited to the installation. Upflow, horizontal or downflow applications may be used.

The supply air duct should be properly sized by use of a transition to match unit opening. Refer to Table 1 for air handler unit inlet and outlet dimensions.

⚠ CAUTION

Use 1/2" screws to connect duct work to unit. Longer screws will pierce the drain pan and cause leakage. If pilot holes are drilled, drill only through field duct and unit bottom duct flange.

Duct work that is not designed to match the supply air opening can cause turbulence inside the plenum. This turbulence can change the air flow patterns across the electric heater limit switches. If the factory suggested transition cannot be fabricated, it is recommended that a block off plate (approximately 8" high and running the full width of the plenum) be attached to the supply opening. Refer to Figure 8 as a visual aid. The use of this block off plate will enable better air circulation across the limit switches.

AIR FILTERS

Return air filters are required and must be field supplied. Filtration must be accomplished external to the unit.

⚠ CAUTION

Equipment should never be operated without a filter.

SECTION V: ELECTRIC HEATER INSTALLATION

If the air handler requires electric heat, install the electric heat kit according to the installation instructions included with the kit. After installing the kit, mark the air handler nameplate to designate the heater kit that was installed. If no heater is installed, mark the name plate appropriately to indicate that no heat kit is installed.

Use only 6HK Revision C or later heater kits, as listed on air handler name plate and in these instructions. Use data from Tables 4 through 9 for information on required minimum motor speed tap to be used for heating operation and maximum over-current protection device required as listed for combination of air handler and heater kit.

For Upflow, Downflow and Horizontal left-hand applications, the kits can be installed without modification.

Field modification is required for Horizontal right-hand airflow application only. Follow instructions with heater for modification.

NOTICE

In some horizontal applications, the service disconnects on the electric heat kits must be rotated 180° so the up position of the disconnect is the ON position. This service disconnect orientation change is required by UL1995, Article 26.19 (in reference to all circuit breakers).

SECTION VI: LINE POWER CONNECTIONS

Power may be brought into the unit through the supply air end of the unit (top left when unit is vertical) or the left side panel. Use the hole appropriate to the unit's orientation in each installation to bring conduit from the disconnect. The power lead conduit should be terminated at the electrical control box. To determine proper wire sizing, refer to Tables 3, 7-10 and the latest edition of the National Electric Code or in Canada the Canadian electrical Code and local codes to determine correct wire sizing. To minimize air leakage, seal the wiring entry point at the outside of the unit.

All electrical connections to air handlers must be made with copper conductors. **Direct connection of aluminum wiring to air handlers is not approved.**

If aluminum conductors are present, all applicable local and national codes must be followed when converting from aluminum to copper conductors prior to connection to the air handler.

The chosen conductor and connections all must meet or exceed the amperage rating of the overcurrent protector (service disconnect or fuse) in the circuit.

Additionally, existing aluminum wire within the structure must be sized correctly for the application according to National Electric Code and local codes. Caution must be used when sizing aluminum rather than copper conductors, as aluminum conductors are rated for less current than copper conductors of the same size.

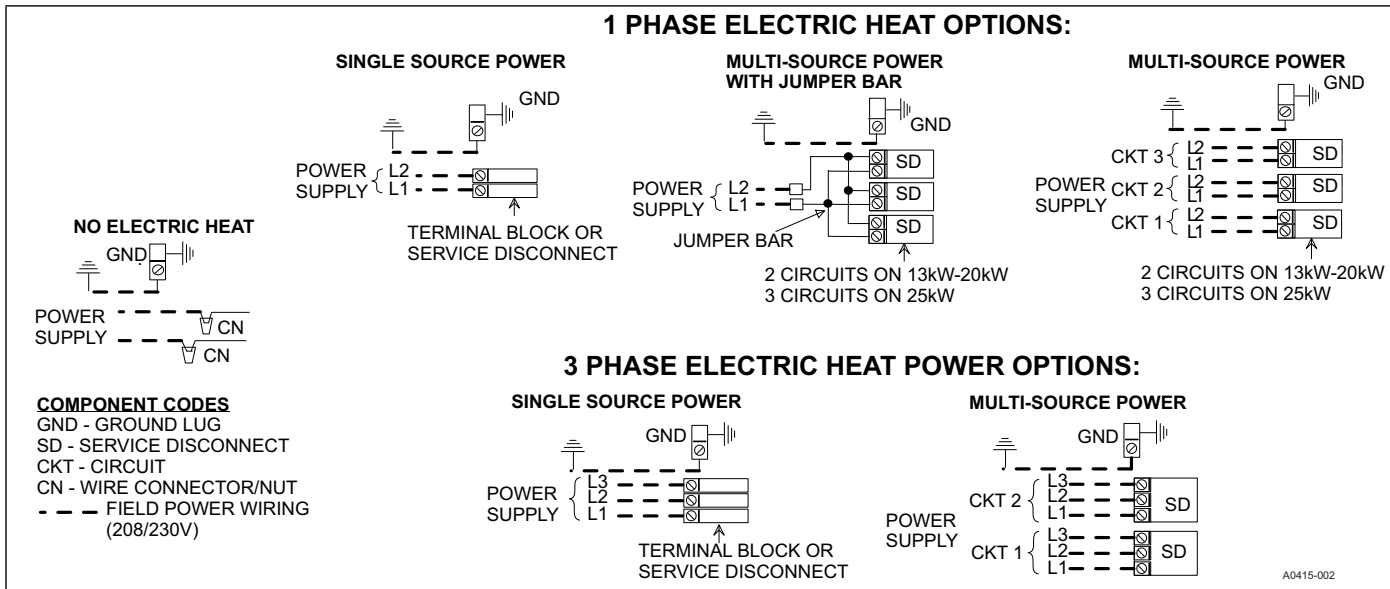

FIGURE 9: Line Power Connections

SECTION VII: LOW VOLTAGE CONTROL CONNECTIONS

The 24 volt power supply is provided by an internally wired low voltage transformer which is standard on all models. If the unit is connected to a 208 volt power supply, the low voltage transformer must be rewired to the 208 volt tap. See the unit wiring diagram.

Field supplied low voltage wiring can exit the unit through the top right (when unit is vertical upflow) or the right side panel. Refer to Figure 5. Remove desired knockout and pierce foil faced insulation to allow wiring to pass through. Use as small of a hole as possible to minimize air leakage. Install a 7/8" plastic bushing in the selected hole and keep low voltage wiring as short as possible inside the control box.

To further minimize air leakage, seal the wiring entry point at the outside of the unit.

The field wiring is to be connected at the pigtails supplied with the air handler. Refer to Figures 11 & 12 for system wiring.

NOTICE

All wiring must comply with local and national electrical code requirements. Read and heed all unit caution labels.

NOTICE

It is possible to vary the amount of electric heat turned on during the defrost cycle of a heat pump. Standard wiring will only bring on the first stage of electric heat during defrost. See Table 6 for additional information on heat during defrost cycle.

SECTION VIII: BLOWER SPEED CONNECTIONS

Adjust blower motor speed to provide airflow within the minimum and maximum limits approved for indoor coil, electric heat and outdoor unit. Make speed tap adjustments at the motor terminal block. Refer to airflow data listed in Table 11. Connect motor wires to motor speed tap receptacle for speed desired.

The standard ECM motor operates when a 24 VAC signal is sent to any of its 5-speed taps. If simultaneous 24 VAC inputs are present, the motor operates at the highest speed tap that is energized. The lowest speed is 1, and the highest speed is 5. The air handler comes factory wired with the electric heat kit connected to tap 5 for the heating speed, and the cooling heat pump connected to tap 4 for the heating speed. The cooling / heat pump indicating speed is supplied by the thermostat "G" signal.

The electric heat kit wire for the heating speed should be moved from 5 to the appropriate speed tap according to Table 4. If electric heat requires speed tap 5, the highest speed tap available for cooling / heat pump heating is tap 4.

If a lower circulating speed is desired for fan only operation (lower than a heating or cooling fan speed), connect the factory "red" wire shipped on tap #4 into the lowest setting desired. Field install a wire from low voltage "YEL," and connect it to the motor speed tap desired for cooling / heat pump heating fan speed.

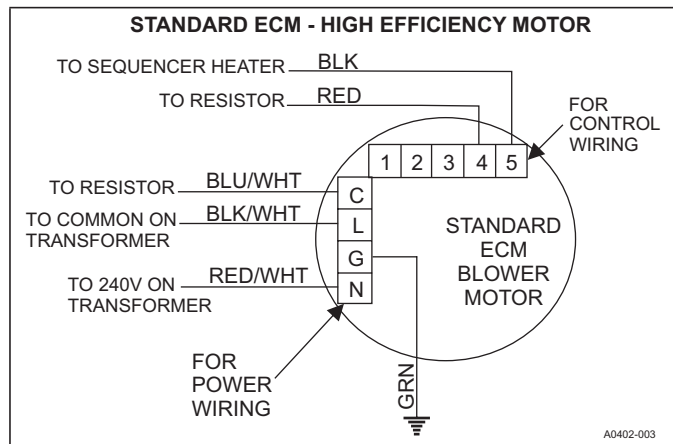

FIGURE 10: Blower Speed Connections

SECTION IX: UNIT DATA

TABLE 2: Physical and Electrical Data - Cooling Only

Models		ME08B	ME12B	ME14D	ME16C	ME20D
Blower - Diameter x Width		10 x 8	10 x 8	11 x 10	11 x 10	11 x 10
Motor	HP	1/3 HP	1/2 HP	1/2 HP	3/4 HP	3/4 HP
	Nominal RPM	1050	1050	1050	1050	1050
Voltage		208/230	208/230	208/230	208/230	208/230
Full Load Amps @230V		2.6	3.8	3.8	5.4	5.4
Filter ¹	Type	DISPOSABLE OR PERMANENT				
	Size	16 x 20 x 1	16 x 20 x 1	22 x 20 x 1	20 x 20 x 1	22 x 20 x 1
	Bottom Rack Kit	1BR01117	1BR01117	1BR01124	1BR01121	1BR01124
	Permanent Type Kit	1PF0601	1PF0601	1PF0603	1PF0602	1PF0603
Shipping / Operating Weight (lbs.)		52/51	52/51	75/74	68/67	75/74

1. Field supplied.

TABLE 3: Electrical Data - Cooling Only

Models	Motor FLA ¹	Minimum Circuit Ampacity	MOP ²
ME08B	2.6	3.3	15
ME12B / ME14D	3.8	4.8	
ME16C / ME20D	5.4	6.8	

1. FLA = Full Load Amps.

2. MOP = Maximum Overcurrent Protection device; must be HACR type circuit breaker or time delay fuse. Refer to the latest edition of the National Electric Code or in Canada the Canadian electrical Code and local codes to determine correct wire sizing.

TABLE 4: Electrical Heat: Minimum Fan Speed

Heater Kit Models ^{1,2,3}	Nom. kW @240V	Air Handler Models				
		ME08B	ME12B	ME14D	ME16C	ME20D
6HK(0,1)6500206	2.4kW	Med Lo (#2)	Med Lo (#2)	Med Lo (#2)	Med Lo (#2)	Med Lo (#2)
6HK(0,1)6500506	4.8kW	Med (#3)	Med Lo (#2)	Med Lo (#2)	Med Lo (#2)	Med Lo (#2)
6HK(0,1)6500806	7.7kW	Med Hi (#4)	Med Lo (#2)	Med (#3)	Med Lo (#2)	Med Lo (#2)
6HK(0,1)6501006 6HK36501025	9.6kW	Med Hi (#4)	Med Lo (#2)	Med (#3)	Med Lo (#2)	Med Lo (#2)
6HK(1,2)6501306	12.5kW	Hi (#5)	Med Hi (#4)	Med (#3)	Med Lo (#2)	Med Lo (#2)
6HK(1,2)6501506 6HK36501525	14.4kW	–	Hi (#5)	Med (#3)	Med Lo (#2)	Med Lo (#2)
6HK(1,2)6501806 6HK36501825	17.3kW	–	Hi (#5)	Med Hi (#4)	Med (#3)	Med (#3)
6HK(1,2)6502006 6HK46502025	19.2kW	–	Hi (#5)	–	Med Hi (#4)	Med (#3)
6HK(1,2)6502506 6HK46502525	24kW	–	–	–	–	Med (#3)

1. (0,1) - 0 = no service disconnect OR 1 = with service disconnect.

2. (1,2) - 1 = with service disconnect, no breaker jumper bar OR 2 = with service disconnect & breaker jumper bar.

3. 6HK3 = 3-Phase with terminal block connectors only, 6HK4 = 3-Phase with service disconnect.

TABLE 5: KW & MBH Conversions - For Total Power Input Requirement

For a power distribution voltage that is different than the provided nominal voltage, multiply the kW and MBH data from the table by the conversion factor in the following table.

DISTRIBUTION POWER	NOMINAL VOLTAGE	CONVERSION FACTOR
208V	240V	0.75
220V	240V	0.84
230V	240V	0.92

TABLE 6: Electric Heat Performance Data: 208/230-1-60 & 208/230-3-60

Heater Models ^{1,2,3}		Nominal kW @240V	Total Heat ⁴				kW Staging			
			kW		MBH		W1 Only		W1 + W2	
			208V	230V	208V	230V	208V	230V	208V	230V
1PH	6HK(0,1)6500206	2.4	1.8	2.2	6.2	7.5	1.8	2.2	1.8	2.2
	6HK(0,1)6500506	4.8	3.6	4.4	12.3	15	3.6	4.4	3.6	4.4
	6HK(0,1)6500806	7.7	5.8	7.1	19.7	24.1	5.8	7.1	5.8	7.1
	6HK(0,1)6501006	9.6	7.2	8.8	24.6	30.1	7.2	8.8	7.2	8.8
	6HK(1,2)6501306	12.5	9.4	11.5	32	39.2	3.1	3.8	9.4	11.5
	6HK(1,2)6501506	14.4	10.8	13.2	36.9	45.1	3.6	4.4	10.8	13.2
	6HK(1,2)6501806	17.3	13	15.9	44.3	54.2	6.5	7.9	13	15.9
	6HK(1,2)6502006	19.2	14.4	17.6	49.2	60.2	7.2	8.8	14.4	17.6
3PH	6HK(1,2)6502506	24	18	22	61.5	75.2	7.2	8.8	18	22
	6HK36501025	9.6	7.2	8.8	24.6	30.1	7.2	8.8	7.2	8.8
	6HK36501525	14.4	10.8	13.2	36.9	45.1	10.8	13.2	10.8	13.2
	6HK36501825	17.3	13	15.9	44.3	54.2	13	15.9	13	15.9
	6HK46502025	19.2	14.4	17.6	49.2	60.2	7.2	8.8	14.4	17.6
6HK46502525	24	18	22	61.5	75.2	9	11	18	22	

- (0,1) - 0 = no service disconnect OR 1 = with service disconnect.
- (1,2) - 1 = with service disconnect, no breaker jumper bar OR 2 = with service disconnect & breaker jumper bar.
- 6HK3 = 3-Phase with terminal block connectors only, 6HK4 = 3-Phase with service disconnect
- For different power distributions, see conversion table above.

TABLE 7: Electrical Data For Single Source Power Supply: 208/230-1-60

Air Handler Models	Heater Models ^{1,2}	Heater Amps @240V	Field Wiring			
			Min. Circuit Ampacity		MOP. ³	
			208V	230V	208V	230V
ME08B	6HK(0,1)6500206	10	14.9	16.1	15	20
	6HK(0,1)6500506	20	25.8	28.0	30	30
	6HK(0,1)6500806	32	39.0	42.7	40	45
	6HK(0,1)6501006	40	47.4	52.0	50	60
	6HK(1,2)6501306	52	60.6	66.6	70	70
ME12B	6HK(0,1)6500206	10	16.8	18.0	20	20
	6HK(0,1)6500506	20	27.6	29.9	30	30
	6HK(0,1)6500806	32	40.9	44.6	45	45
	6HK(0,1)6501006	40	49.3	53.8	50	60
	6HK(1,2)6501306	52	62.5	68.5	70	70
	6HK(1,2)6501506	60	70.9	77.7	80	80
	6HK(1,2)6501806	72	84.1	92.4	90	100
	6HK(1,2)6502006	80	92.5	101.7	100	110
ME14D	6HK(0,1)6500206	10	16.8	18.0	20	20
	6HK(0,1)6500506	20	27.6	29.9	30	30
	6HK(0,1)6500806	32	40.9	44.6	45	45
	6HK(0,1)6501006	40	49.3	53.8	50	60
	6HK(1,2)6501306	52	62.5	68.5	70	70
	6HK(1,2)6501506	60	70.9	77.7	80	80
	6HK(1,2)6501806	72	84.1	92.4	90	100

For notes, see Page 10.

TABLE 7: Electrical Data For Single Source Power Supply: 208/230-1-60 (Continued)

Air Handler Models	Heater Models ^{1,2}	Heater Amps @240V	Field Wiring			
			Min. Circuit Ampacity		MOP. ³	
			208V	230V	208V	230V
ME16C	6HK(0,1)6500206	10	19.3	20.5	20	25
	6HK(0,1)6500506	20	30.1	32.4	35	35
	6HK(0,1)6500806	32	43.4	47.1	45	50
	6HK(0,1)6501006	40	51.8	56.3	60	60
	6HK(1,2)6501306	52	65.0	71.0	70	80
	6HK(1,2)6501506	60	73.4	80.2	80	90
	6HK(1,2)6501806	72	86.6	94.9	90	100
	6HK(1,2)6502006	80	95.0	104.2	100	110
ME20D	6HK(0,1)6500206	10	19.3	20.5	20	25
	6HK(0,1)6500506	20	30.1	32.4	35	35
	6HK(0,1)6500806	32	43.4	47.1	45	50
	6HK(0,1)6501006	40	51.8	56.3	60	60
	6HK(1,2)6501306	52	65.0	71.0	70	80
	6HK(1,2)6501506	60	73.4	80.2	80	90
	6HK(1,2)6501806	72	86.6	94.9	90	100
	6HK(1,2)6502506	100	116.7	128.1	125	150

1. (0,1) - maybe 0 (no service disconnect) or 1 (with service disconnect).

2. (1,2) maybe 1 (with service disconnect, no breaker jumper bar) or 2 (with service disconnect & breaker jumper bar).

3. MOP = Maximum Overcurrent Protection device; must be HACR type service disconnect or time delay fuse. Refer to the latest edition of the National Electric Code or in Canada the Canadian electrical Code and local codes to determine correct wire sizing.

TABLE 8: Electrical Data For Multi-source Power Supply: 208/230-1-60

Air Handler Models	Heater Models	Heater Amps @240V	Min. Circuit Ampacity						MOP. ¹					
			208V			230V			208V			230V		
			Circuit						Circuit					
			1st ³	2nd	3rd	1st ³	2nd	3rd	1st ³	2nd	3rd	1st ³	2nd	3rd
ME08B	6HK16501306	52	22.9	37.6	-	24.9	41.5	-	25	40	-	25	45	-
ME12B	6HK16501306	52	24.8	37.6	-	26.8	41.5	-	25	40	-	30	45	-
	6HK16501506	60	27.7	43.3	-	30.0	47.9	-	30	45	-	30	50	-
	6HK16501806	72	45.0	39.0	-	49.1	43.1	-	45	40	-	50	45	-
	6HK16502006	80	49.3	43.3	-	53.9	47.9	-	50	45	-	60	50	-
ME14D	6HK16501306	52	24.8	37.6	-	26.8	41.5	-	30	40	-	30	45	-
	6HK16501506	60	27.7	43.3	-	30.0	47.9	-	30	45	-	30	50	-
	6HK16501806	72	45.0	39.0	-	49.1	43.1	-	45	40	-	50	45	-
ME16C	6HK16501306	52	27.3	37.6	-	29.3	41.5	-	30	40	-	30	45	-
	6HK16501506	60	30.2	43.3	-	32.5	47.9	-	35	45	-	35	50	-
	6HK16501806	72	47.5	39.0	-	51.6	43.1	-	50	40	-	60	45	-
	6HK16502006	80	51.8	43.3	-	56.4	47.9	-	60	45	-	60	50	-
ME20D	6HK16501306	52	27.3	37.6	-	29.3	41.5	-	30	40	-	30	45	-
	6HK16501506	60	30.2	43.3	-	32.5	47.9	-	35	45	-	35	50	-
	6HK16501806	72	47.5	39.0	-	51.6	43.1	-	50	40	-	60	45	-
	6HK16502006	80	51.8	43.3	-	56.4	47.9	-	60	45	-	60	50	-
	6HK16502506	100	51.8	43.3	21.7	56.4	47.9	24.0	60	45	25	60	50	25

1. MOP = Maximum Overcurrent Protection device; must be HACR type circuit breaker or time delay fuse. The 1st circuit includes blower motor amps. Refer to the latest edition of the National Electric Code or in Canada the Canadian electrical Code and local codes to determine correct wire sizing.

TABLE 9: Electrical Data For Single Source Power Supply: 208/230-3-60

Air Handler Models	Heater Models ^{1,2}	Heater Amps @240V	Field Wiring			
			Min. Circuit Ampacity		MOP. ³	
			208V	230V	208V	230V
ME08B	6HK36501025	23.1	28.3	30.9	30	35
ME12B	6HK36501025	23.1	29.8	32.4	30	35
	6HK36501525	34.6	42.2	46.2	45	50
	6HK36501825	41.6	49.8	54.6	50	55
	6HK46502025 ²	46.2	54.8	60.1	55	70
ME14D	6HK36501025	23.1	29.8	32.4	30	35
	6HK36501525	34.6	42.2	46.2	45	50
	6HK36501825	41.6	49.8	54.6	50	55
ME16C	6HK36501025	23.1	31.8	34.4	35	35
	6HK36501525	34.6	44.2	48.2	45	50
	6HK36501825	41.6	51.8	56.6	55	60
	6HK46502025 ²	46.2	56.8	62.1	60	70
ME20D	6HK36501025	23.1	31.8	34.4	35	35
	6HK36501525	34.6	44.3	48.2	45	50
	6HK36501825	41.6	51.9	56.7	55	60
	6HK46502025 ²	46.2	56.8	62.0	60	70
	6HK46502525 ²	57.7	69.3	75.9	70	80

1. 6HK3 = 3-Phase with terminal block connections only, 6HK4 = 3-Phase with service disconnect.
2. The 20kW and 25kW heater models (6HK46502025 and 6HK46502525) come with circuit breakers standard. Single source power MCA and MOP requirements are given here only for reference if used with field installed single point power modification (S1-32436041000).
3. MOP = Maximum Overcurrent Protection device; must be HACR type circuit breaker or time delay fuse. The 1st circuit includes blower motor amps. Refer to the latest edition of the National Electric Code or in Canada the Canadian electrical Code and local codes to determine correct wire sizing.

TABLE 10: Electrical Data For Multi-source Power Supply: 208/230-3-60

Air Handler Models	Heater Models ¹	Heater Amps @240V	Min. Circuit Ampacity				MOP. ²			
			208V		230V		208V		230V	
			Circuit				Circuit			
			1st ³	2nd	1st ³	2nd	1st ³	2nd	1st ³	2nd
ME12B	6HK46502025	46.2	29.8	25.0	32.4	27.6	30	25	35	30
ME16C	6HK46502025	46.2	31.8	25.0	34.4	27.6	35	25	35	30
ME20D	6HK46502025	46.2	31.8	25.0	34.4	27.6	35	25	35	30
	6HK46502525	57.7	38.0	31.3	41.3	34.6	40	35	45	35

1. The 20kW and 25kW heater models (6HK46502025 and 6HK46502525) come with circuit breakers standard.
2. MOP = Maximum Overcurrent Protection device; must be HACR type circuit breaker or time delay fuse. The 1st circuit includes blower motor amps. Refer to the latest edition of the National Electric Code or in Canada the Canadian electrical Code and local codes to determine correct wire sizing.

TABLE 11: Air Flow Data (CFM)¹

Models	CM Models	Blower Motor Speed	External Static Pressure (in. wc.)						
			0.10	0.20	0.30	0.40	0.50	0.60	0.70
ME08B	CM18B	#5 HI	939	893	871	837	804	767	714
		#4 MED-HI	833	803	765	737	697	639	587
		#3 MED	638	605	576	494	454	380	278
		#2 MED-LO	538	489	456	374	283	211	157
		#1 LO	478	446	367	272	211	150	23
	CM24B	#5 HI	923	892	862	833	797	743	688
		#4 MED-HI	846	816	786	750	710	638	599
		#3 MED	631	605	575	512	442	370	282
		#2 MED-LO	570	530	460	402	328	232	186
		#1 LO	477	448	372	292	203	157	24
	CM30B	#5 HI	937	905	877	841	798	748	704
		#4 MED-HI	846	808	778	733	667	636	572
		#3 MED	638	609	556	495	463	399	336
		#2 MED-LO	560	484	469	408	321	265	201
		#1 LO	481	448	390	328	252	166	92
ME12B	CM18B	#5 HI	1355	1334	1302	1270	1231	1201	1170
		#4 MED-HI	1273	1244	1213	1177	1142	1109	1073
		#3 MED	1074	1041	1009	974	936	894	809
		#2 MED-LO	862	826	798	766	688	607	587
		#1 LO	659	616	560	512	457	387	275
	CM24B	#5 HI	1359	1331	1301	1269	1234	1202	1171
		#4 MED-HI	1272	1245	1209	1174	1143	1106	1073
		#3 MED	1072	1040	1007	973	937	874	778
		#2 MED-LO	857	821	794	756	676	613	567
		#1 LO	654	606	557	504	443	379	271
	CM30B	#5 HI	1354	1325	1294	1263	1230	1198	1168
		#4 MED-HI	1268	1235	1203	1171	1139	1107	1075
		#3 MED	1069	1038	1003	974	935	876	781
		#2 MED-LO	859	818	794	756	681	620	563
		#1 LO	654	608	552	503	434	364	289
	CM36B	#5 HI	1348	1317	1285	1254	1222	1189	1157
		#4 MED-HI	1258	1225	1192	1160	1126	1093	1063
		#3 MED	1062	1029	993	964	929	879	778
		#2 MED-LO	860	822	791	761	682	616	568
		#1 LO	642	599	554	502	431	367	294
ME14D	CM30D	#5 HI	1583	1546	1516	1477	1435	1401	1364
		#4 MED-HI	1499	1456	1426	1393	1349	1306	1267
		#3 MED	1295	1247	1217	1181	1135	1080	1005
		#2 MED-LO	1099	1075	1026	983	909	840	786
		#1 LO	906	875	834	754	675	589	521
	CM36D	#5 HI	1604	1563	1524	1479	1450	1410	1374
		#4 MED-HI	1508	1464	1428	1384	1350	1308	1271
		#3 MED	1300	1250	1209	1175	1132	1075	1006
		#2 MED-LO	1102	1058	1028	986	909	838	784
		#1 LO	912	884	831	763	694	568	530
	CM42D	#5 HI	1544	1520	1482	1440	1411	1367	1321
		#4 MED-HI	1455	1426	1393	1349	1305	1272	1207
		#3 MED	1263	1238	1197	1157	1100	1033	980
		#2 MED-LO	1074	1037	993	946	877	810	729
		#1 LO	888	853	787	736	644	571	508

Continued on next page.

TABLE 11: Air Flow Data (CFM)¹

Models	CM Models	Blower Motor Speed	External Static Pressure (in. wc.)						
			0.10	0.20	0.30	0.40	0.50	0.60	0.70
ME16C	CM36C	#5 HI	1776	1735	1700	1657	1617	1577	1529
		#4 MED-HI	1701	1663	1621	1583	1538	1497	1453
		#3 MED	1522	1475	1442	1394	1349	1301	1245
		#2 MED-LO	1297	1250	1203	1151	1101	1050	957
		#1 LO	1112	1052	1002	951	854	816	756
	CM42C	#5 HI	1754	1719	1678	1644	1599	1562	1513
		#4 MED-HI	1676	1637	1599	1562	1517	1476	1423
		#3 MED	1495	1454	1411	1371	1328	1280	1233
		#2 MED-LO	1286	1235	1198	1143	1097	1036	992
		#1 LO	1119	1055	1006	948	900	804	752
	CM48C	#5 HI	1769	1727	1689	1650	1608	1568	1525
		#4 MED-HI	1692	1648	1605	1568	1525	1485	1440
		#3 MED	1554	1505	1461	1420	1373	1326	1273
		#2 MED-LO	1308	1256	1213	1164	1088	1007	941
		#1 LO	1116	1057	1007	955	839	792	741
	CM60C	#5 HI	1794	1757	1720	1686	1639	1589	1545
		#4 MED-HI	1700	1664	1624	1582	1543	1496	1443
		#3 MED	1530	1484	1444	1402	1356	1314	1257
		#2 MED-LO	1305	1257	1217	1162	1115	1060	993
		#1 LO	1124	1060	1008	954	889	827	755
ME20D	CM36D	#5 HI	2061	2021	1979	1938	1904	1865	1829
		#4 MED-HI	1998	1949	1914	1879	1835	1797	1756
		#3 MED	1769	1711	1677	1643	1603	1570	1530
		#2 MED-LO	1557	1508	1469	1439	1398	1355	1323
		#1 LO	1340	1291	1252	1216	1170	1132	1058
	CM42D	#5 HI	2032	1996	1959	1913	1890	1849	1820
		#4 MED-HI	1974	1938	1892	1855	1824	1785	1754
		#3 MED	1752	1706	1680	1633	1591	1546	1511
		#2 MED-LO	1545	1505	1468	1432	1393	1351	1307
		#1 LO	1340	1296	1260	1219	1169	1118	1055
	CM48D	#5 HI	2062	2024	1993	1952	1910	1868	1836
		#4 MED-HI	2006	1958	1932	1890	1850	1815	1770
		#3 MED	1785	1741	1698	1646	1610	1582	1538
		#2 MED-LO	1564	1521	1477	1443	1398	1362	1323
		#1 LO	1350	1305	1257	1226	1181	1112	1029
	CM60D	#5 HI	1998	1959	1923	1888	1862	1826	1786
		#4 MED-HI	1933	1887	1855	1811	1791	1757	1719
		#3 MED	1703	1670	1633	1592	1567	1531	1485
		#2 MED-LO	1522	1474	1447	1403	1370	1328	1281
		#1 LO	1306	1260	1223	1190	1131	1078	1012
CM64D	#5 HI	1940	1897	1868	1832	1806	1770	1728	
	#4 MED-HI	1883	1860	1829	1789	1761	1728	1688	
	#3 MED	1686	1648	1619	1584	1537	1508	1466	
	#2 MED-LO	1490	1446	1415	1385	1346	1298	1236	
	#1 LO	1279	1248	1206	1167	1113	1062	972	

1. Air handler units have been tested to UL 1995 / CSA 22.2 No. 236 standards up to 0.50" wc. external static pressure.

Dry coil conditions only, tested without filters.

For optimal performance, external static pressures of 0.2" to 0.5" are recommended. Heating applications tested at 0.50" w.c. esp.

Airflow data shown is from testing performed at 230V. AE units use a standard ECM constant torque motor, and there is minimal variation of airflow at other distribution voltage values. The above data can be used for airflow at other distribution voltages.

SECTION X: MAINTENANCE

Filters must be cleaned or replaced when they become dirty. Inspect at least once per month. The frequency of cleaning depends upon the hours of operation and the local atmospheric conditions. Clean filters keep unit efficiency high.

COIL CLEANING

If the coil needs to be cleaned, it should be cleaned with water.

LUBRICATION

The bearings of the blower motor are permanently lubricated.

CONDENSATE DRAINS

During the cooling season check the condensate drain lines to be sure that condensate is flowing from the primary drain but not from the secondary drain. If condensate ever flows from the secondary drain the unit should be promptly shut off and the condensate pan and drains cleaned to insure a free flowing primary drain.

SECTION XI: AIR SYSTEM ADJUSTMENT

To check the Cubic Feet per Minute (CFM), measure the static pressure drop across the air handler using a manometer and static pressure tips. To prepare coil for static pressure drop measurements run the fan only to assure a dry coil.

NOTICE

Refer to Table 9 for coil Air Flow Data of Cubic Feet Per Minute (CFM). Run the fan on the highest speed to be used.

Drill 2 holes, one 12" away from the air handler in the supply air duct and on 12" away from the air handler in the return air duct (before any elbows in the duct work). Insert the pressure tips and read the pressure drop from the manometer. See Table 9 to determine the air flow, and make the necessary adjustments to keep the CFM within the airflow limitations of the coil.

EXTERNAL DUCT STATIC

Measure the supply air static pressure. Record this positive number. Measure the return air static pressure. Record this negative number. Treat the negative number as a positive, and add the two numbers together. This is total system static. If a filter rack is installed on the return air end of the air handler or indoor coil section, the return air duct static must be measured between the filter and the indoor coil.

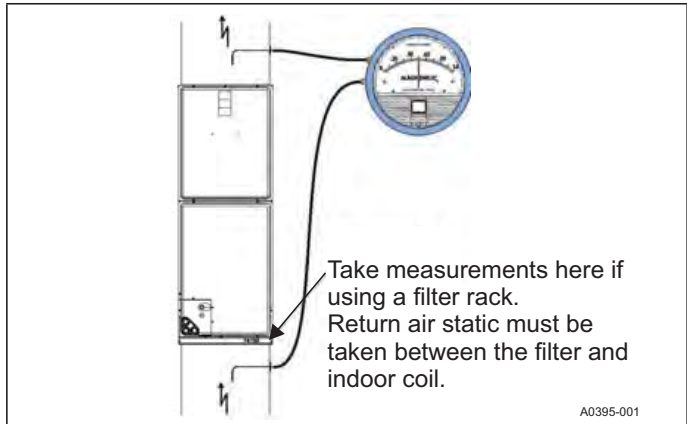

SECTION XII: TYPICAL THERMOSTAT CONNECTIONS

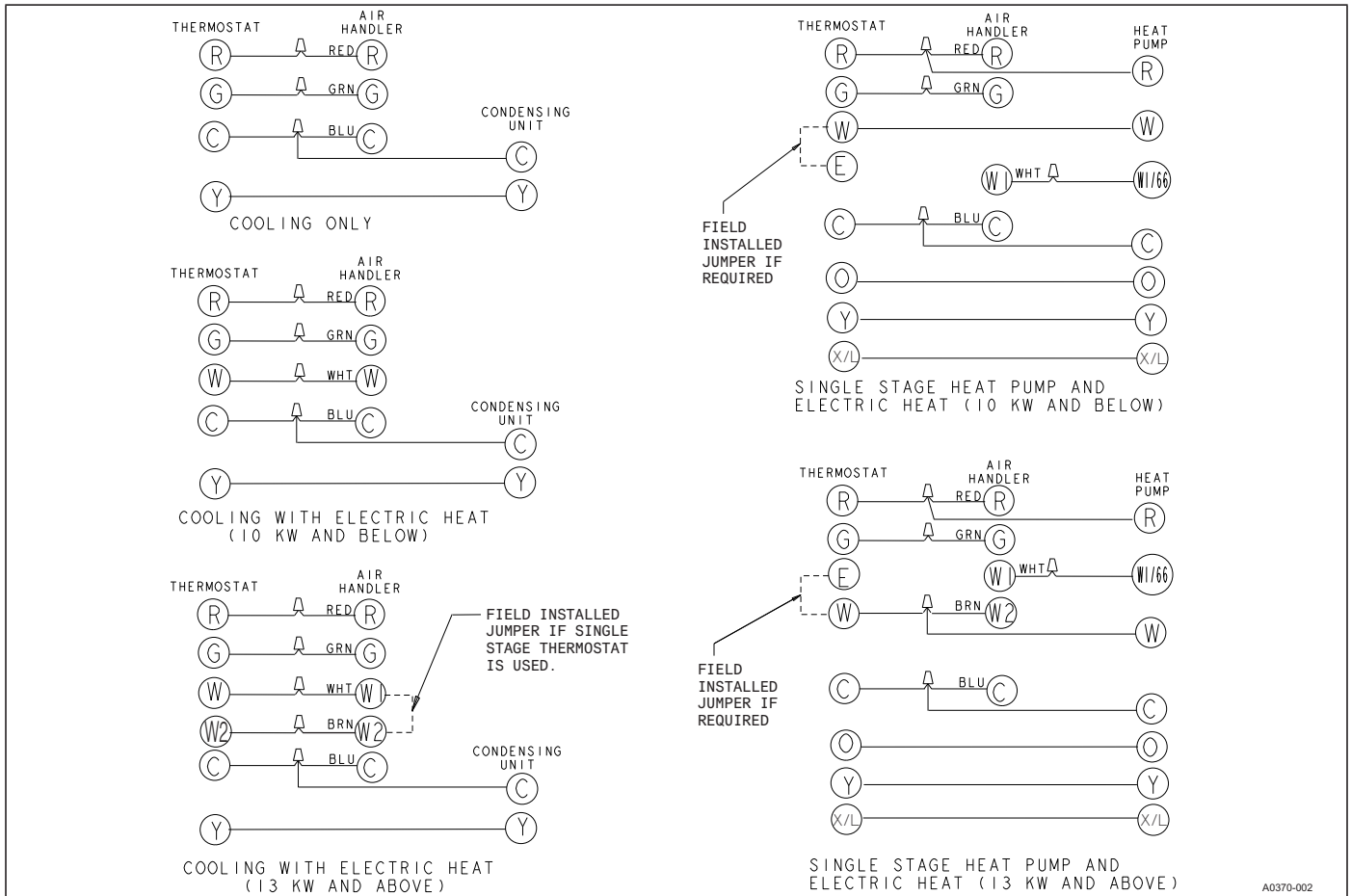

FIGURE 11: Typical Thermostat Wiring Diagram - ECM

SECTION XIII: WIRING DIAGRAM

WHEN INSTALLING HEATER KIT, BE SURE THE BLOWER SPEED IS SET TO THE SPEED SPECIFIED FOR THE AIR HANDLER/HEATER KIT COMBINATION ON THIS UNIT'S INSTALLATION INSTRUCTIONS. SEE INSTALLATION INSTRUCTIONS FOR PROPER LOW VOLTAGE FIELD WIRING CONNECTIONS.

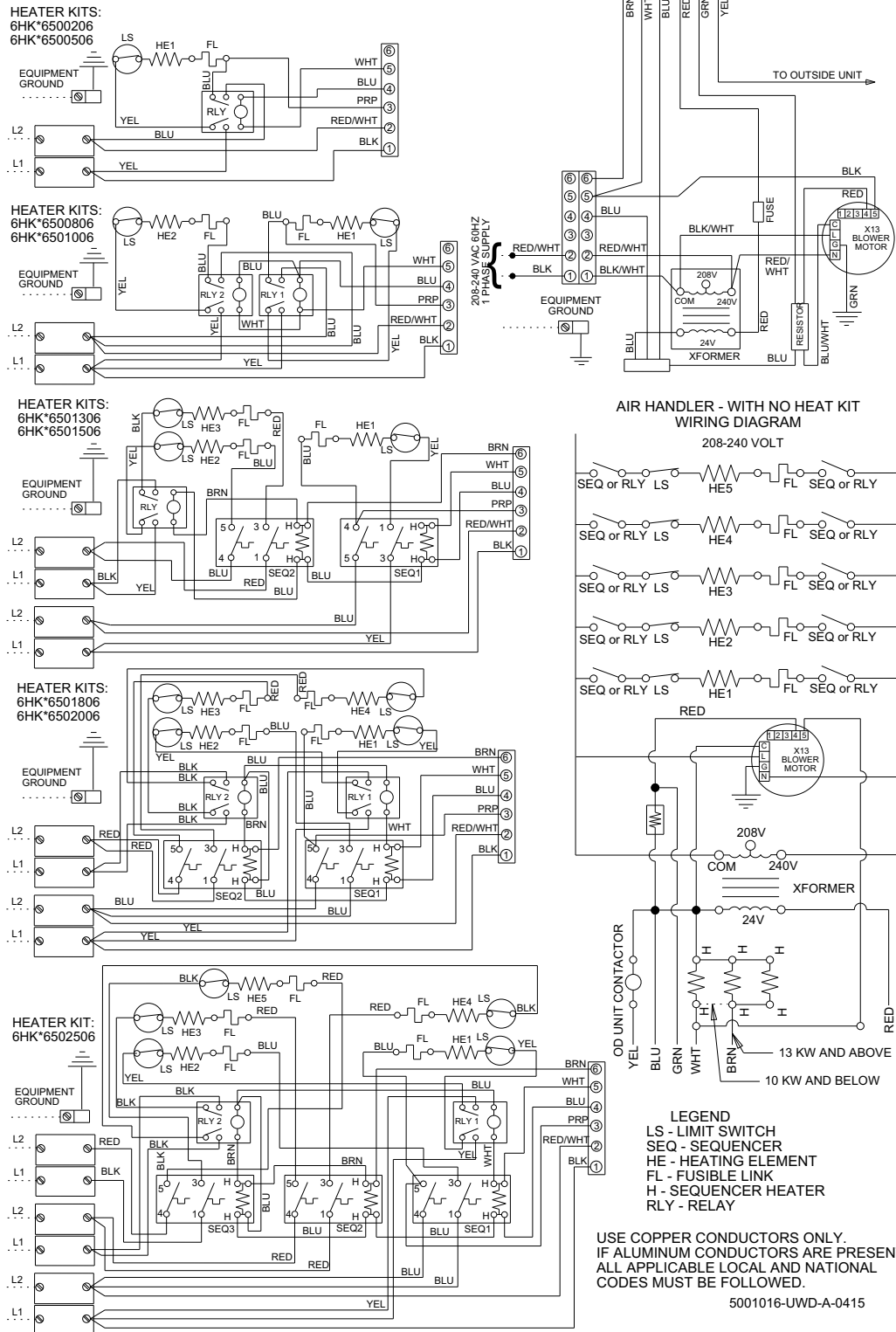

FIGURE 12: Wiring Diagram - Standard ECM - Single Phase Heat Kits

3 PHASE ELECTRIC HEAT KITS

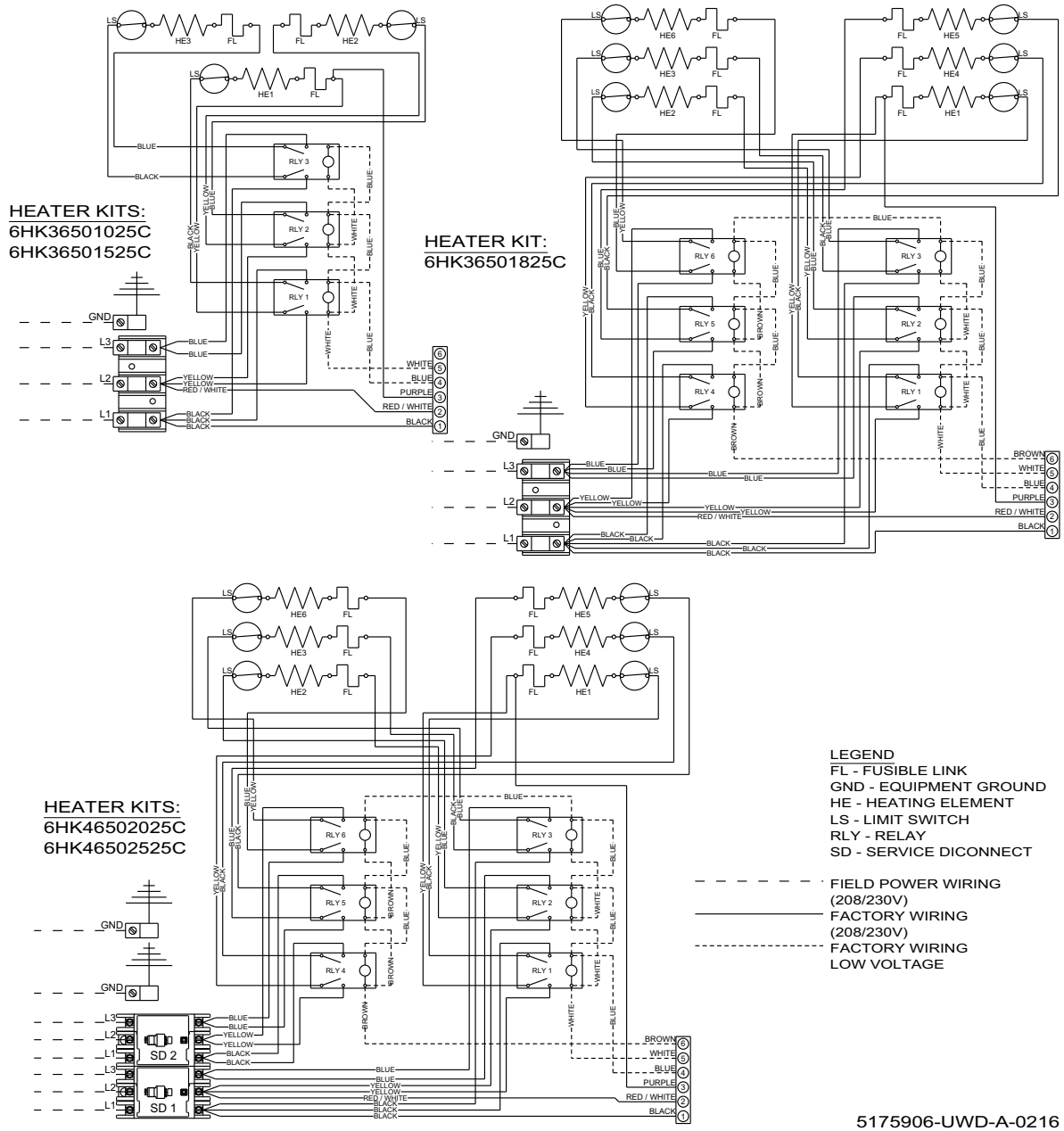

FIGURE 13: Wiring Diagram - Three Phase Heat Kits

SECTION XIV: TYPICAL THERMOSTAT CONNECTIONS

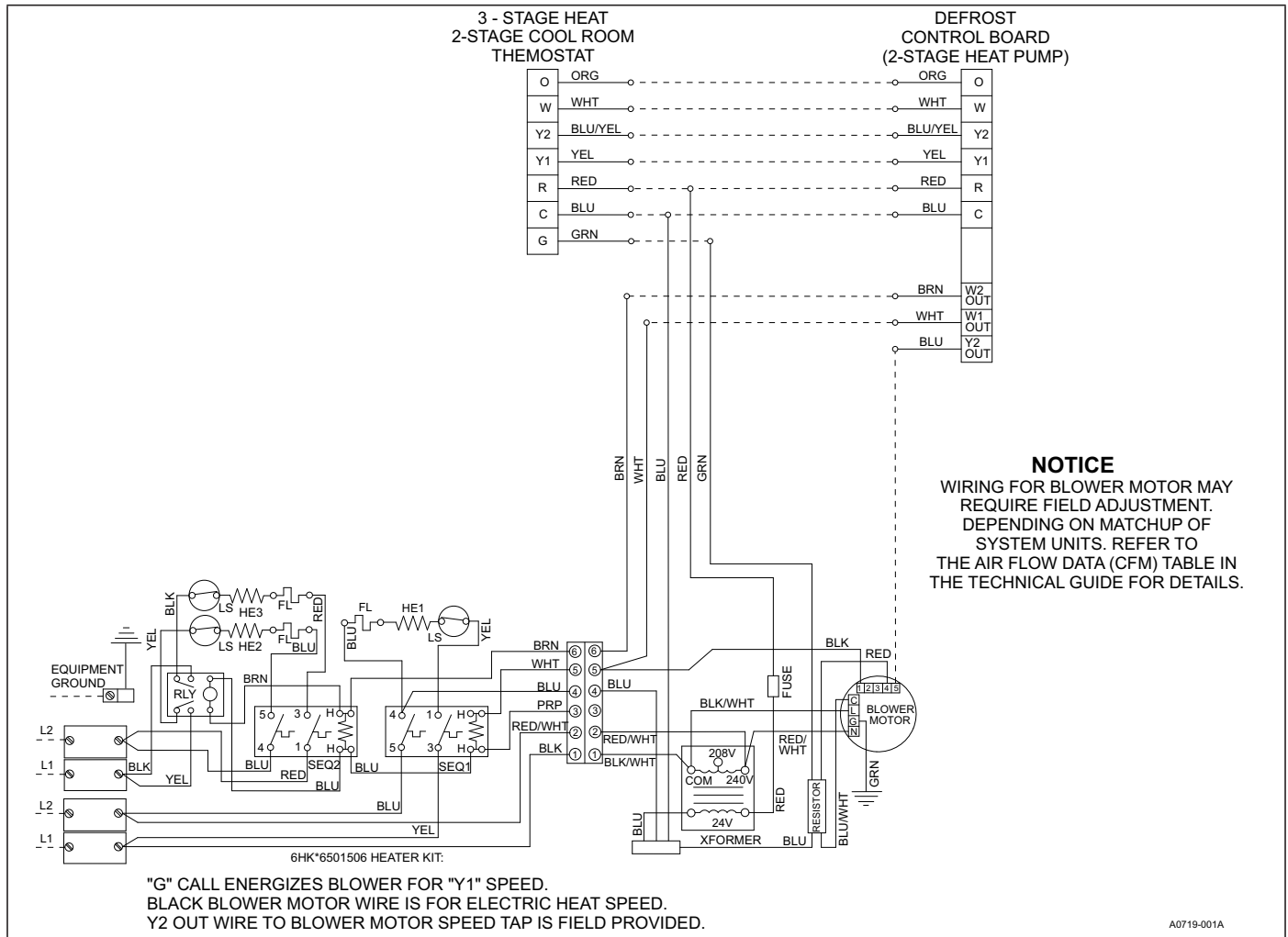

FIGURE 14: Typical Thermostat Wiring Diagram - 2 Stage Heat Pump with ECM Blower Motor

NOTES

SECTION XV: START UP SHEET

<input type="button" value="Print Form"/>	Residential Air Handler with Electric Heat Start-Up Sheet	<input type="button" value="Reset Form"/>
Proper start-up is critical to customer comfort and equipment longevity		
Start-Up Date <input style="width: 100px;" type="text"/>	Company Name <input style="width: 200px;" type="text"/>	Start-Up Technician <input style="width: 200px;" type="text"/>
Owner Information		
Name <input style="width: 150px;" type="text"/>	Address <input style="width: 250px;" type="text"/>	Daytime Phone <input style="width: 100px;" type="text"/>
City <input style="width: 100px;" type="text"/>	State or Province <input style="width: 100px;" type="text"/>	Zip or Postal Code <input style="width: 100px;" type="text"/>
Equipment Data		
Unit Model # <input style="width: 150px;" type="text"/>	Unit Serial # <input style="width: 200px;" type="text"/>	
General Information (Check all that apply)		
<input type="radio"/> New Construction	<input type="radio"/> Up flow	<input type="radio"/> Horizontal Left
<input type="radio"/> Retrofit	<input type="radio"/> Down flow	<input type="radio"/> Horizontal Right
Unit Location and Connections (Check all that apply)		
<input type="checkbox"/> Unit is level	<input type="checkbox"/> Duct connections are complete:	<input type="checkbox"/> Supply <input type="checkbox"/> Return
<input type="checkbox"/> Condensate drain properly connected per the installation instructions	<input type="checkbox"/> Condensate trap has been primed with water	
Filters		
<input type="checkbox"/> Filters installed	Number of filters <input style="width: 50px;" type="text"/>	Filter size <input style="width: 50px;" type="text"/>
Electrical Connections & Inspection (Complete all that apply)		
<input type="radio"/> 208 volts AC	<input type="radio"/> 230 volt AC	
<input type="checkbox"/> Inspect wires and electrical connections	<input type="checkbox"/> Transformer wired properly for primary supply voltage	<input type="checkbox"/> Ground connected
Line Voltage Measured (Volts AC) <input style="width: 80px;" type="text"/>	Low voltage value between "R" and "C" at control board (Volts AC) <input style="width: 80px;" type="text"/>	
<input type="checkbox"/> Thermostat wiring is complete <input type="checkbox"/> Thermostat cycle rate or heat anticipator adjusted to Installation Manual specifications		
Air Flow Setup		
Blower Type & Set-Up	<input type="radio"/> ECM	COOL <input type="radio"/> A <input type="radio"/> B <input type="radio"/> C <input type="radio"/> D
		ADJUST <input type="radio"/> A <input type="radio"/> B <input type="radio"/> C <input type="radio"/> D
		DELAY <input type="radio"/> A <input type="radio"/> B <input type="radio"/> C <input type="radio"/> D
		HEAT <input type="radio"/> A <input type="radio"/> B <input type="radio"/> C <input type="radio"/> D
	<input type="radio"/> X-13	<input type="radio"/> 1 <input type="radio"/> 2 <input type="radio"/> 3 <input type="radio"/> 4 <input type="radio"/> 5
<input type="radio"/> PSC	<input type="radio"/> Low <input type="radio"/> Medium Low <input type="radio"/> Medium <input type="radio"/> Medium High <input type="radio"/> High	
Supply static (inches of water column) <input style="width: 50px;" type="text"/>	Supply air dry bulb temperature <input style="width: 50px;" type="text"/>	Outside air dry bulb temperature <input style="width: 50px;" type="text"/>
Return static (inches of water column) <input style="width: 50px;" type="text"/>	Return air dry bulb temperature <input style="width: 50px;" type="text"/>	Return air wet bulb temperature <input style="width: 50px;" type="text"/>
Total external static pressure <input style="width: 50px;" type="text"/>	Temperature drop <input style="width: 50px;" type="text"/>	Supply air wet bulb temperature <input style="width: 50px;" type="text"/>
Other Jumpers (Check all that apply)		
HUM STAT <input type="radio"/> YES <input type="radio"/> NO	AC/HP <input type="radio"/> AC <input type="radio"/> HP	CONT FAN <input type="radio"/> L <input type="radio"/> M <input type="radio"/> H
Continued on next Page		

Electric Heat (Complete all that apply)

Electric heat kit - Model number <input type="text"/>		Serial number <input type="text"/>		Rated KW <input type="text"/>	
Number of elements <input type="text"/>	Measured Amperage	Heater 1 <input type="text"/>	Heater 2 <input type="text"/>	Heater 3 <input type="text"/>	
		Heater 4 <input type="text"/>	Heater 5 <input type="text"/>	Heater 6 <input type="text"/>	
	Measured Voltage	Heater 1 <input type="text"/>	Heater 2 <input type="text"/>	Heater 3 <input type="text"/>	
		Heater 4 <input type="text"/>	Heater 5 <input type="text"/>	Heater 6 <input type="text"/>	
Heating return air dry bulb temperature <input type="text"/>	Heating supply air dry bulb temperature <input type="text"/>	Air temperature rise <input type="text"/>			

Clean Up Job Site

Job site has been cleaned, indoor and outdoor debris removed from job site

Tools have been removed from unit

All panels have been installed

Unit Operation and Cycle Test (Complete all that apply)

Operate the unit through continuous fan cycles from the thermostat, noting and correcting any problems

Operate the unit through cooling cycles from the thermostat, noting and correcting any problems

Operate the unit through mechanical heating cycles from the thermostat, noting and correcting any problems

Operate the unit through emergency heating cycles from the thermostat, noting and correcting any problems

Owner Education

Provide owner with the owner's manual

Explain operation of system to equipment owner

Explain thermostat use and programming (if applicable) to owner

Explain the importance of regular filter replacement and equipment maintenance

Comments and Additional Job Details