

TECHNICAL GUIDE

**SINGLE PACKAGE
HEAT PUMP/GAS HEAT**
14 SEER - R-410A - 208/230V - 1 PHASE
2 TO 5 NOMINAL TON
50 TO 125 MBH HEAT INPUT
MODELS: PHG4*24 TO 60



Due to continuous product improvement, specifications are subject to change without notice.

Visit us on the web at

www.simplygettingthejobdone.com

Additional rating information can be found at

www.ahridirectory.org

WARRANTY SUMMARY*

Extended 10-year limited parts and compressor warranty.

Lifetime gas heat exchanger warranty with registration.

* Extended warranty requires online registration within 90 days of purchase for replacement or closing for new home purchase. See the limited warranty certificate in the *User's Information Manual* for details.

DESCRIPTION

These packaged dual fuel cooling/gas heating/heat pumps are designed for outdoor installation. Only utility and duct connections are required at the point of installation.

FEATURES

- **Operating Efficiency** - All PHG4 models provide a minimum AFUE of 81% in gas heating and 14 SEER and 8 HSPF ratings for heat pump cooling/heating operation. All models meet the California Low NOx requirements of 40 ng/J emission level for Air Quality Management Districts.
- **On-Site Flexibility** - All model sizes use a compact design cabinet in one of two footprints. This provides installer flexibility for placing the proper capacity unit on curbs or pads with the smallest footprint after the internal load has been determined. Field convertible duct connections from side shot to down shot allow the installer to have greater flexibility with less inventory.
- **Lower Installation Cost** - Installation time and costs are reduced by easy power and control wiring connections. The small base dimension means less space is required on the ground or roof. All units are completely wired, charged with R-410A refrigerant, and tested before shipment. Test stations using a state-of-the-art computerized process system are used to ensure product quality. Refrigerant charge and component part numbers are verified using computers during assembly. Vital run test statistics such as system pressure, motor currents, air velocity and temperature, unit vibration, and gas system safeties are monitored and recorded by the system to ensure unit performance. Equal size side supply and return duct connections allow easy connection of ducts to match low crawl spaces without transition pieces.
- **Utility Connections Made Easy** - Gas and electric utility access is provided through the bottom or the side of the unit. Utility connections can be made quickly and with a minimum amount of field labor. A field supplied and field installed electrical disconnect switch must be installed.
- **Convertible Airflow Design** - The bottom duct openings are covered when they leave the factory, ready to be used for a side supply/side return application. If a bottom supply/bottom return application is required, remove the two panels from the bottom of the unit and place them in the side supply/side return duct openings. No panel cutting is required and no accessory panel is necessary. The convertible airflow design allows maximum field flexibility and minimum inventory.
- **Condensate Pan** - A corrosion-resistant, long-lasting, water-tight pan is positioned below the indoor coil to collect and drain all condensate, preventing build-up of stagnant condensate. The condensate pan conforms to ASHRAE 62-19 standards (Ventilation for Acceptable Indoor Air Quality).
- **Condensate Drain** - The 3/4-in. NPT female connection is rigidly mounted to ensure proper fit and leak-tight seal.
- **Durable Finish** - The cabinet is made of G90 galvanized steel with a powder paint coating for appearance and protection. The pre-treated galvanized steel provides a better paint-to-steel bond, which resists corrosion and rust creep. The powder paint finish ensures less fading when exposed to sunlight, and provides superior corrosion resistance (1,000-h salt spray tested).

Continued on next page.

- **Full Perimeter Base Rails** - The easily removable base rails provide a solid foundation for the entire unit and protect the unit during shipment. The rails allow forklift access from all sides, and rigging holes are also available so an overhead crane can be used to place the units on a roof. On applications where the unit is placed on a pad, the base keeps the unit off the pad to deter corrosion. On applications where height is limited, it is possible to remove the base rails by removing two screws in each corner.
- **More Attractive Appearance** - A single-piece top cover containing a top-discharge outdoor fan arrangement requires less square footage on installation and provides a wider variety of installations. The one-piece design adds greater water integrity. Rounded corners with water drip edges add to the attractive appearance.
- **Top Discharge** - The top-discharge outdoor fan does not disrupt neighboring areas or dry out vegetation surrounding the unit. The warm air from the top mounted fan is blown up and away from the structure and any landscaping. This allows compact location on multi-unit applications.
- **Outdoor Coil Grille** - All models use a stamped slotted design that provides superior impact protection against small objects during transit and after installation.
- **Low Operating Sound Level** - The upward airflow carries the normal operating noise up and away from the living area. The rigid top panel effectively isolates noise. The isolator mounted compressor and the rippled fins of the outdoor coil muffle the normal fan motor and compressor operating sounds. The unique formed base pan also aids in sound attenuation with its structural design. This design strategically places embossments in the pan for optimum strength and rigidity.
- **Fan System** - All models operate over a wide range of design conditions with a standard ECM indoor blower motor. These units easily match all types of applications and provide greater on-site flexibility to match comfort requirements. The cooling speed is factory set and can be field adjusted to an alternate speed. The heating speed is factory set to maintain mid point rise at the unit's heating input, but can be field adjusted. This allows for maximum comfort conditions.
- **Simple Control Circuit** - A low-voltage gas heat printed circuit board contains a status/diagnostic indicator light. Field thermostat wiring connects to color-coded leads using twist-on wire connectors. Cooling controls use contactor and relays for simple application and troubleshooting. MATE-N-LOK® plug connectors are used. The electrical control box is not located in the compressor compartment. The controls are mounted to allow the separate access panel to be removed for troubleshooting and maintenance without affecting the normal system operating pressures. All wiring internal to the unit is numbered and color-coded.
- **Controls** - Demand defrost curves are preloaded into the demand defrost control for optimized performance based on unit capabilities.
- **Protected Compressor** - The compressor is internally protected against high pressure and temperature. This is done by the simultaneous operation of a high-pressure internal relief valve and a temperature sensor, which protects the compressor if undesirable operating conditions occur.
- **Pressure Switches** - A high-pressure switch is standard in all units. When abnormal conditions are sensed through the pressure switch, the unit locks out, preventing any further operation until it is reset or the problem is corrected.
- **Exclusive Coil Design** - The grooved copper tubes and enhanced aluminum fin construction of the outdoor coils improve heat transfer for maximum efficiency and durability. Indoor tube and fin coils have all aluminum construction for reliability and efficient heat transfer.
- **Heat Exchangers** - Gas heat exchangers use corrosion-resistant, stainless-steel tubular construction to provide long-life, trouble-free operation. Gas heat exchangers are offered with lifetime warranties as standard with registration.
- **Post-Purge Induced Draft Combustion** - Exhausts combustion products from the heat exchanger upon completion of the heating cycle to prolong the heat exchanger life.
- **Spark to Burner Ignition** - No pilot assembly is required, providing more consistent ignition in gas heating mode. This ignition system is highly reliable, durable, and eliminates nuisance lockouts.
- **Multi Port In-Shot Burners** - No field adjustment is required to mix the air and gas for natural gas or propane use. These burners are constructed of high-grade corrosion-resistant, aluminumized steel.
- **Low Maintenance** - Long-life, permanently lubricated outdoor fan motor bearings and indoor blower motor bearings need no annual maintenance, adding greater reliability to the unit. The slide-out blower assembly can be easily removed for cleaning.
- **Easy Service Access** - Individual access panels covering the electrical and gas controls, compressor, and blower section make servicing easy. Removing these panels allows easy removal of components such as the blower assembly for maintenance and troubleshooting.
- **Replacement Parts** - The installer requires no special training to replace any of the components of these units, and the number of new components has been reduced to minimize the inventory of unique parts.
- **Loss of Charge Switch** - All models include a loss of charge switch to provide safe shutdown of the compressor.

NOMENCLATURE

PHG	4	B	42	100	2	X	4	A
1	2	3	4	5	6	7	8	9
1. Model Family PHG - packaged heat pump with gas heat PCG - packaged A/C with gas heat PCE - packaged A/C with electric heat PHE - packaged heat pump with electric heat					5. Gas Heating Input BTU/h x 1000 100 = 100,000 BTU/h input, blank = electric heat			
2. Nominal Cooling Efficiency 4 = 14 SEER, 6 = 16 SEER					6. Voltage-Phase-Frequency 2 = 208/230-1-60, 3 = 208/230-3-60, 4 = 460-3-60			
3. Cabinet Size A = small 35.75 in. x 51.25 in., B = large 45.75 in. x 51.25 in.					7. NOx Approval X = Low NOx, blank = not Low NOx			
4. Nominal Air Conditioning Cooling Capacity BTU/h x 1000 24 = 24,000 BTU/h, 30 = 30,000 BTU/h					8. Generation Level 1 = first generation, 2 = second generation			
Example: PHG4B421002X4A is a packaged heat pump with gas heat, 14 SEER, large cabinet, 3.5 ton, 100,000 BTU/h gas heat, 208/230 V, single-phase, Low NOx model, fourth generation, original release.					9. Revision Level A = original release, B = second release			

COMPONENT LOCATION

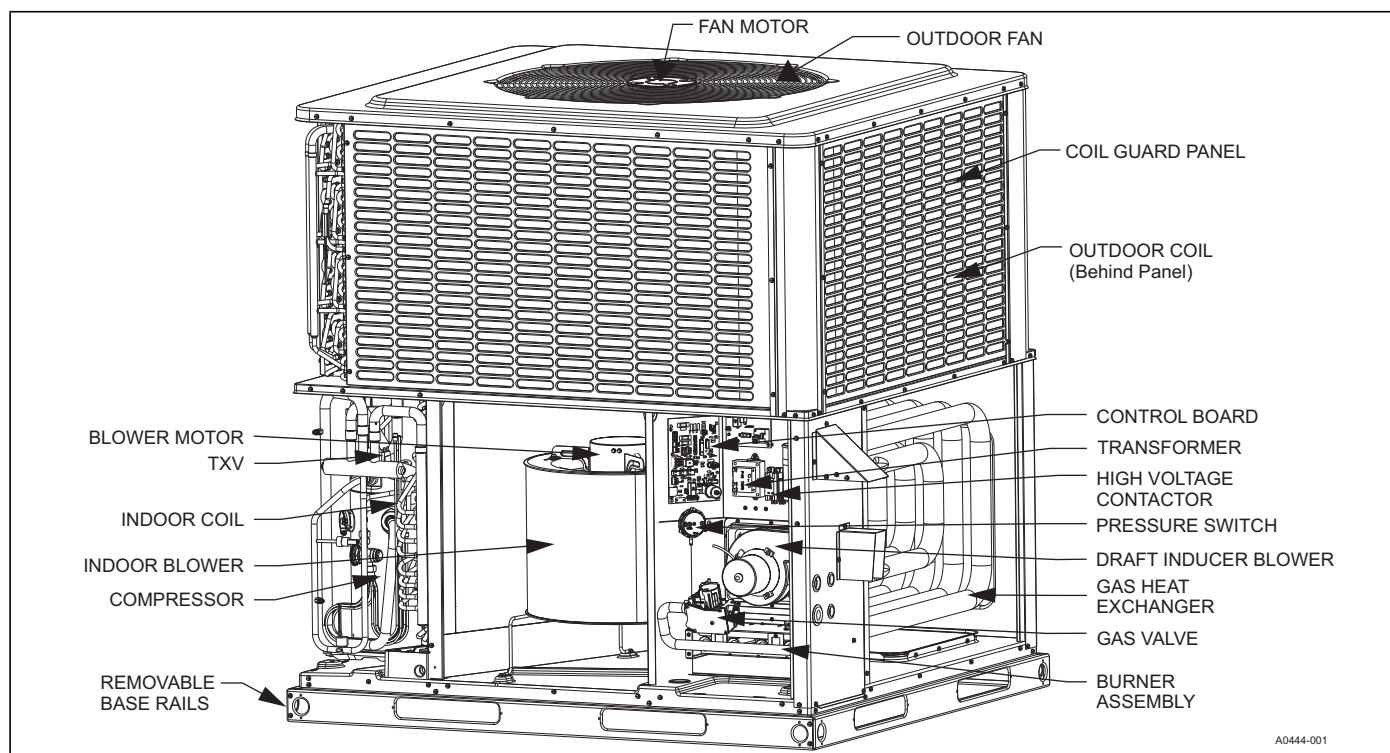

UNIT LIMITATIONS

Model	Unit Voltage	Unit Limitations		
		Applied Voltage		Outdoor DB Temperature
		Minimum	Maximum	Maximum (°F)
PHG4A24	208/230-1-60	187	252	125
PHG4A30	208/230-1-60	187	252	125
PHG4B36	208/230-1-60	187	252	125
PHG4B42	208/230-1-60	187	252	125
PHG4B48	208/230-1-60	187	252	125
PHG4B60	208/230-1-60	187	252	125

APPLICATIONS AND ACCESSORIES

Packaged Equipment Series	Application Limitations							
	Air Temperature at Outdoor Coil (°F)				Air Temperature at Indoor Coil (°F)			
	Minimum		Maximum		Minimum		Maximum	
	DB Cool	DB Heat	DB Cool	DB Heat	WB Cool	DB Heat	WB Cool	DB Heat
14 SEER HP*	55	-10	125	75	57	50	72	80

Note:*PHE4A24 and PHG4A24 models are restricted to operation of 0°F outdoor air temperature.

- **Anchor Bracket Kit (S1-1HK0601)** - This kit firmly anchors PCG, PCE, PHE, and PHG packaged units to a pad or support structure. When correctly installed, the kit is approved for ground-mounted or roof-mounted applications, wind load certified, and listed with the State of Florida. See <https://floridabuilding.org> for this listing.
- **Flue Exhaust Extension Kit (S1-1FE0422, S1-1FE0417)** - The purpose of this kit is to divert flue gas up and away from walkways or fresh air intakes. Use the kit when installing PCG or PHG packaged units if required.
- **Propane Conversion Kit (S1-1NP0703, S1-1NP0704)** - The kit includes burner orifices and gas valve conversion and installation instructions necessary to field convert the unit from natural gas to propane.
- **Economizer for Downflow Applications (S1-2EE04710024, S1-2EE04710124)** - The modulating integrated economizer provides simultaneous operation between the mechanical cooling and economizer operation. The independent blade design ensures proper control and less than 1% leak rate. Includes hood and mesh bird screen filter integrated into the hood, dry bulb sensor, and barometric relief damper. Separate field accessories of single enthalpy and dual enthalpy are also available.
- **Economizer for Horizontal Applications (S1-2EE04710224, S1-2EE04710324)** - The modulating integrated economizer provides simultaneous operation between the mechanical cooling and economizer operation. The independent blade design ensures proper control and less than 1% leak rate. Includes hood and mesh bird screen filter integrated into the hood and dry bulb sensor. Separate field accessories of single enthalpy and dual enthalpy are also available.
- **Barometric Relief Hood (S1-1RD0501)** - Used in conjunction with a horizontal economizer, the barometric relief hood helps to equalize the building pressure caused by the fresh air introduced through the economizer fresh air hood.
- **Single/Dual Enthalpy Sensor (S1-HE-69630NS-2D)** - The sensor replaces the supply air temperature dry bulb sensor that is standard in the economizer kit. The sensor provides improved economizer operation by sensing the dry bulb temperature of indoor supply air plus the enthalpy content of the outdoor air.
- **Duct/Unit Mount CO₂ Kit (S1-2AQ04700924)** - The sensor kit detects CO₂ levels automatically and overrides the economizer when CO₂ levels rise above the preset limits.
- **Wall Mount CO₂ Kit (S1-2AQ04701024)** - The sensor kit detects CO₂ levels automatically and overrides the economizer when CO₂ levels rise above the preset limits.
- **Supply Air Temperature Sensor Kit (S1-TE-63616E-2D)** - The outdoor supply air temperature sensor kit is used with economizers.
- **Filter/Frame Kit (S1-1FF0602, S1-1FF0601)** - The kit contains the necessary hardware to field install return air filters into the base unit. The filter rack is suitable for 1-in. filters or 2-in. filters.

- **Filter (S1-02647812000)** - Washable 1-in. filter. Two filters are required for A base units. Three filters are required for B base units.
- **Motorized Fresh Air Damper (S1-2MD04705224, S1-2MD04705124)** - This is designed for duct mounted side supply/return and unit mounted down supply/return applications. The damper is capable of providing 0% to 50% of outdoor air (field supplied). The damper closes on power loss and includes hood and screen assembly.
- **Rectangle to Round (Horizontal) Adapter (S1-1AK0110, S1-1AK0111)** - The kit includes one supply and one return air rectangle to round duct adapter. Adapters are preformed and designed to fit over current horizontal duct openings on the base unit. The transition is from rectangle to 12 in. round for the 1AK0110 kit and from rectangle to 14 in. round for the 1AK0111 kit.
- **Rectangle to Round (Downflow) Adapter (S1-1AK0108, S1-1AK0109)** - The kit includes one supply and one return air rectangle to round duct adapter. Adapters are preformed and designed to fit into current downflow duct openings on the roof curb. The transition is from rectangle to 16 in. round for the 1AK0108 kit and from rectangle to 18 in. round for the 1AK0109 kit.
- **Roof Curbs (S1-1RC0503, S1-1RC0501)** - NRCA-approved curbs provide proper fit to the base unit for rooftop installations. Curbs are designed to be assembled through hinge pins in each corner. The kit also provides seal strip to ensure an air tight seal. These are 8-in. high roof curbs.
- **Roof Curbs (S1-1RC0504, S1-1RC0502)** - NRCA-approved curbs provide proper fit to the base unit for rooftop installations. Curbs are designed to be assembled through hinge pins in each corner. The kit also provides seal strip to ensure an airtight seal. These are 14-in. high roof curbs.
- **Transition Curb Kits (S1-1TC01*)** - These adapter kits allow field use of existing installed roof curbs, matching the PHG4 footprint to Affinity roof curbs or Carrier, Trane, or Goodman roof curbs. Curb adapters are optional for current generation Carrier replacements, but are recommended for previous generation applications. Refer to the PHG4 *Price Pages* for more details.
- **Manual Outdoor Damper (S1-1FA0502, S1-1FA0501)** - The damper provides 0% to 50% outdoor air capability (field adjustable). The damper is designed for duct mounted side supply/return applications and includes hood and screen assembly.
- **Thermostat** - Compatible thermostat controls are available through accessory sourcing. For optimum performance, these outdoor units are fully compatible with the residential Hx™ Touch Screen Thermostat available through Source 1. For more information, refer to the *Thermostats & Controllers* section of the *Offering Catalog*.
- **Wall Thermostat** - The units are designed to operate with standard, 24-V electronic and electromechanical thermostats. All units can operate with single-stage heat/single-stage cool thermostats - with or without the economizer.
- **Low Ambient Kit (S1-2LA04701024)** - The kit provides necessary hardware to convert the unit to operate in cooling cycle down to 0°F. Standard unit operation is 55°F.
- **Base Rail Hole Cover Kit (S1-1HC0101)** - The kit provides necessary hardware to close off openings in base rails to block off openings and prevent animal entrance.

* For additional kit numbers, refer to the *Price Pages*.

GUIDE SPECIFICATIONS

GENERAL

Units are manufactured by Ducted Systems in an ISO 9001 certified facility. Packaged units give you the flexibility and choice you need in today's market. These packaged cooling/heating air conditioners are designed for outdoor installation. Only utility and duct connections are required at the point of installation. The single-stage gas-fired heaters have stainless steel tubular heat exchangers and spark to burner ignition. They are available in natural gas with field conversion to propane.

DESCRIPTION

Units are factory-assembled, single packaged, heat pumps with electric cooling/gas heating units, designed for outdoor installation. They have built-in, equal size, field convertible duct connections for supply/return or horizontal supply/return. The units are factory wired, piped, charged with R-410A refrigerant, and factory tested before shipment. All unit wiring is both numbered and color-coded. All models are rated in accordance with DOE and AHRI test procedures for heating and cooling operation. Units are CSA listed and classified to ANSI Z21.47/CAN/CSA 2.3 standards and UL 1995/CAN/CSA No. 236-M90 standards.

- **Operating Efficiency** - All heat pump models are rated at 14.0 SEER and 8.0 HSPF for heat pump cooling and heating operation. All models are rated at 81.0% AFUE for gas heating operation.
- **Low Operating Sound Level** - The upward airflow carries the normal operating noise up and away from the living area. The rigid top panel effectively isolates noise. The isolator mounted compressor and the rippled fins of the outdoor coil muffle the normal fan motor and compressor operating sounds. The unique formed base pan also aids in sound attenuation with its structural design. Sound ratings as tested under AHRI test procedures are less than 77 dB(A) for all models.

UNIT CABINET

The unit cabinet is a single-piece design, with drip edges and no-seam corners to provide optimum water integrity. The unit has a rigidly mounted outdoor coil guard to provide protection from objects and personnel after installation. The indoor blower section is insulated with foil-faced or foam insulation, fastened to prevent insulation from entering the air stream. Cabinet panels are separate and easily removable for servicing and maintenance. The unit is built on a formed design base pan, with embossments at critical points to add strength and rigidity and aid in minimizing sound. Full perimeter base rails are provided to ensure reliable transit of equipment and facilitate overhead rigging, allowing truck access and proper sealing on roof curb applications. Base rails are easily removable if their removal is required to lower unit height. Filters are field installed, field provided, and accessible through a removable access door, sealed airtight. The unit's vertical discharge and return duct configuration is designed to fit between standard 24-in. O.C. beams without modification to the building structure, duct work, and base unit. The condensate pan is internally sloped and conforms to ASHRAE 62-19 self-draining standards, with 3/4-in. NPT female ridged mount connection.

- **Durable Finish** - The cabinet is made of G90 galvanized steel with a powder paint coating for appearance and protection. The pretreated galvanized steel provides a better paint-to-steel bond, which resists corrosion and rust creep. The powder paint finish provides superior corrosion resistance (1,000 hour salt spray tested).
- **On-Site Flexibility** - All model sizes use a compact design cabinet in one of two footprints. This provides installer flexibility for placing the proper capacity unit on curbs or pads with the smallest footprint after the internal load has been determined. Field convertible duct connections from side shot to down shot allow the installer to have greater flexibility with less inventory.
- **Attractive Appearance** - A single-piece top cover containing a top-discharge outdoor fan arrangement is used. This requires less square footage on installation and provides a wider variety of installations. The one-piece design adds greater water integrity. Rounded corners with water drip edges add to the attractive appearance and prevent water penetration.
- **Convertible Airflow Design** - The bottom duct openings are covered when they leave the factory, ready to be used for a side supply/side return application. If a bottom supply/bottom return application is required, remove the two panels from the bottom of the unit and place them in the side supply/side return duct openings. No panel cutting is required and no accessory panel is necessary. The convertible airflow design allows maximum field flexibility and minimum inventory.
- **Utility Connections Made Easy** - Electric utility access is provided through the bottom or the side of the unit. Utility connections must be made quickly and with a minimum amount of field labor. A field supplied and field installed electrical disconnect switch must be installed.
- **Easy Service Access** - Individual access panels provide access to all major components, such as compressors, indoor coils, blowers, controls/gas heating sections, and filters, making servicing easy. Removing these panels allows easy removal of components such as the blower assembly, for maintenance and troubleshooting.
- **Top Discharge** - The top-discharge outdoor fan does not disrupt neighboring areas or dry out vegetation surrounding the unit. The warm air from the top mounted fan is blown up and away from the structure and any landscaping.
- **Outdoor Coil Grille** - All models use a stamped slotted design that provides superior impact protection against small objects during transit and after installation.

Indoor Blower Assembly - The blower is a direct drive design. The blower wheel is of the double-inlet type with forward-curved blades, dynamically balanced to operate smoothly throughout the entire range of operation. The airflow design is constant air volume. Bearings are sealed and permanently lubricated for longer life and no maintenance. The blower assembly is a slide-out design for easy removal and cleaning. Indoor blower motors are equipped with a standard high-efficiency brushless DC motor (constant torque), also known as a standard ECM motor.

Outdoor Fan Assembly - The outdoor fan is of the direct-driven propeller type, discharges air vertically, has aluminum blades riveted to a corrosion resistant steel spider bracket, and is statically balanced for smooth operation. The outdoor fan motor is totally enclosed with permanently lubricated bearings and internally protected against overload conditions.

REFRIGERANT COMPONENTS

- **Protected Compressor** - The compressor is a fully hermetic type, direct drive compressor, which is internally protected against high pressure and temperature. This is done by the simultaneous operation of a high-pressure internal relief valve and a temperature sensor, which protects the compressor if undesirable operating conditions occur. The hermetic motor is suction gas cooled and has a voltage range of $\pm 10\%$ of the unit nameplate voltage. Compressors have internal isolation and sound muffling to minimize vibration and noise, and are externally isolated on a dedicated, independent mounting.
- **Indoor Coils** - Indoor coils have a direct expansion, draw through design, and have aluminum plate fins mechanically bonded to seamless internally-enhanced aluminum tubes with all joints brazed.
- **Condensate Pan** - A corrosion-resistant, long-lasting, water-tight pan is positioned below the indoor coil to collect and drain all condensate, preventing build-up of stagnant condensate. The condensate pan conforms to ASHRAE 62-19 standards (Ventilation for Acceptable Indoor Air Quality).
- **Condensate Drain** - The 3/4-in. NPT female connection is rigidly mounted to ensure proper fit and leak-tight seal.
- **Outdoor Coils** - Outdoor coils have aluminum plate fins mechanically bonded to seamless internally-enhanced copper tubes with all joints brazed, and have a draw through design.

Refrigerant Circuit and Refrigerant Safety Components include the following:

- Thermal expansion valve (TXV) that is factory mounted and provided
- Filter/strainer to eliminate any foreign matter
- Reversing valves to control refrigerant flow

GAS HEATING SECTION

The heat exchanger and exhaust system are constructed of corrosion-resistant materials and designed with induced draft combustion with post-purge logic and a redundant main gas valve. The heat exchanger is of the tubular type, constructed of stainless steel for corrosion resistance and allowing a minimum mixed air entering temperature of 40°F. Burners are of the in-shot type, constructed of aluminumized steel. All gas piping enters the unit cabinet at a single location through either the side or bottom, without any field modifications. An integrated control board provides timed control of indoor blower functionality and burner ignition. The heating section is provided with the following minimum protection:

- Primary high-temperature limit switch
- Induced draft pressure switch
- Flame roll out switch or switches (manual reset)
- Flame proving controls

All gas heat models meet the California requirement for emissions of less than 40 ng/J (California requirement on single-phase models only).

CONTROLS

- **Simple Control Circuit** - Field thermostat wiring connects to color-coded leads using twist-on wire connections. Cooling controls use contactor and relays for simple application and troubleshooting. MATE-N-LOK plug connectors are used. Heating controls consist of a direct spark ignition control and demand defrost heat pump control. The electrical control box is not located in the compressor compartment. The controls are mounted to allow the separate access panel to be removed for troubleshooting and maintenance without affecting the normal system operating pressures. All wiring internal to the unit is numbered and color-coded.
- **Pressure Switches** - A high-pressure switch is standard in all units. When abnormal conditions are sensed through the pressure switch, the unit locks out, preventing any further operation until it is reset or the problem is corrected.
- **Factory Testing** - Installation time and costs are reduced by easy power and control wiring connections. All units are completely wired, charged with R-410A, and tested before shipment. Test stations using a state-of-the-art computerized process system are used to ensure product quality. Refrigerant charge and component part numbers are verified using computer bar code scans during assembly. Vital run test statistics such as system pressure, motor currents, air velocity and temperature, unit vibration, and gas system safeties are monitored and recorded by the system to ensure unit performance. This data can be provided by serial number tracking if requested.

Spark to Burner Ignition - No pilot assembly is required, providing more consistent ignition in gas heating mode. This ignition is highly reliable and durable and eliminates nuisance lockouts.

PHYSICAL DATA

MODELS	PHG4A24	PHG4A30	PHG4B36	PHG4B42	PHG4B48	PHG4B60		
NOMINAL TONNAGE	2.0	2.5	3.0	3.5	4.0	5.0		
AHRI Cooling Performance								
Gross capacity at AHRI A point (MBH)	25.3	30.1	36.3	42.8	49.1	61.3		
AHRI net capacity (MBH)	25.0	29.6	35.8	42.0	48.0	59.5		
EER	11.6	11.6	11.6	11.6	11.6	11.6		
SEER	14.0	14.0	14.0	14.0	14.0	14.0		
Nominal CFM	780	950	1150	1350	1500	1850		
System power (kW)	1.96	2.2	2.7	3.2	3.8	4.7		
Refrigerant type	R-410A	R-410A	R-410A	R-410A	R-410A	R-410A		
Refrigerant charge (lb-oz)	4-9	7-4	9-6	9-6	14-4	11-10		
AHRI Heat Pump Heating Performance								
47°F capacity rating (MBH)	23.6	28.2	34.8	39.0	46.5	56.5		
System power (kW/COP)	3.7	3.7	3.6	3.6	3.7	3.6		
17°F capacity rating (MBH)	13.6	15.6	19.8	23.0	27.0	33.0		
HSPF (BTU/Watts-hr.)	8.0	8.0	8.0	8.0	8.0	8.0		
AHRI Gas Heat Performance								
Heating model	75	75	100	65	100	100	125	125
Heat input (KBTU)	75.0	75.0	100.0	65.0	100.0	100.0	125.0	125.0
Heat output (KBTU)	60	60	80	52	80	80	100	100
AFUE (%)	81.0	81.0	81.0	81.0	81.0	81.0	81.0	81.0
Number of burners	3	3	3	2	3	3	4	4
Number of stages	1	1	1	1	1	1	1	1
Temperature rise range (°F)	40-70	40-70	40-70	40-70	40-70	40-70	40-70	40-70
Maximum static pressure W.C.	0.5	0.5	0.5	0.5	0.5	0.5	0.5	0.5
Maximum outlet air temperature (°F)	180	180	180	180	180	180	180	180
Gas piping connection (in.)	1/2	1/2	1/2	1/2	1/2	1/2	1/2	1/2
Dimensions (in.)								
Length	51 1/4	51 1/4	51 1/4	51 1/4	51 1/4	51 1/4	51 1/4	
Width	35 3/4	35 3/4	45 3/4	45 3/4	45 3/4	45 3/4	45 3/4	
Height	44	45	47	47	53	55	55	
Operating Weight (lb)	357	416	477	497	499	542	544	550
Compressors								
Type	Scroll	Scroll	Scroll	Scroll	Scroll	Scroll	Scroll	
Outdoor Coil Data								
Face area (ft ²)	12.3	13.8	17.6	17.6	24.7	26.4		
Rows	1	2	2	2	2	2		
Fins per inch	22	22	22	22	22	22		
Tube diameter (mm)	7	7	7	7	7	7		
Circuitry type	Interlaced	Interlaced	Interlaced	Interlaced	Interlaced	Interlaced		
Refrigerant control	TXV	TXV	TXV	TXV	TXV	TXV		
Indoor Coil Data								
Face area (ft ²)	4.6	4.6	6.3	6.3	6.3	6.3		
Rows	3	3	3	3	4	4		
Fins per inch	16	16	16	16	16	16		
Tube diameter (in.)	3/8	3/8	3/8	3/8	3/8	3/8		
Circuitry type	Interlaced	Interlaced	Interlaced	Interlaced	Interlaced	Interlaced		
Refrigerant control	TXV	TXV	TXV	TXV	TXV	TXV		
Outdoor Fan Data								
Fan diameter (in.)	24	24	26	26	26	26		
Type	Prop	Prop	Prop	Prop	Prop	Prop		
Drive type	Direct	Direct	Direct	Direct	Direct	Direct		
Number of speeds	1	1	1	1	1	1		
Motor HP each	1/4	1/4	1/3	1/3	1/3	1/3		
RPM	850	850	850	850	850	850		
Nominal total CFM	2800	2850	3450	3450	4000	4000		
Direct Drive Indoor Fan Data								
Fan size (in.)	11 x 8	11 x 8	11 x 10	11 x 10	11 x 10	11 x 10		
Type	Centrifugal	Centrifugal	Centrifugal	Centrifugal	Centrifugal	Centrifugal		
Motor HP each	1/2	1/2	1/2	3/4	3/4	1		
RPM	1200 Maximum	1200 Maximum	1200 Maximum	1200 Maximum	1200 Maximum	1200 Maximum		
Frame size	48	48	48	48	48	48		
Filters								
Filter size	A	A	B	B	B	B		
Quantity - size	Field-supplied external filters must be sized so as not to exceed 300 fpm air velocity through disposable filters. For internal filter use, a filter rack kit is available. Refer to the instructions supplied with the kit for replacement filter sizes. Filter sizes: A = 20 in. x 20 in., B = 20 in. x 30 in.							

COOLING PERFORMANCE DATA - 2 TON																
PACKAGED UNIT MODEL NO.		PHG4A24														
CONDENSER ENTERING AIR TEMPERATURE (°F)	ID CFM	600					800					1000				
		80	80	75	80	80	80	80	75	80	80	80	80	75	80	80
		57	62	62	67	72	57	62	62	67	72	57	62	62	67	72
55 / 45	T.C.	26.4	28.7	29.0	32.4	35.1	29.4	30.9	31.3	34.9	37.0	32.3	33.0	33.6	37.5	39.0
	S.C.	26.2	28.7	20.0	20.4	16.8	29.3	30.8	23.2	23.4	18.6	32.3	33.0	26.3	26.5	20.4
	K.W.	1.08	1.25	1.05	1.03	1.00	1.05	1.30	1.03	1.02	0.99	1.03	1.35	1.02	1.00	0.99
65 / 55	T.C.	24.8	26.7	26.7	30.3	32.8	27.6	28.4	28.5	32.5	34.6	30.5	30.2	30.2	34.6	34.2
	S.C.	24.7	26.6	18.6	19.3	15.6	27.6	28.4	21.5	22.3	17.3	30.5	30.1	24.3	25.2	19.0
	K.W.	1.23	1.41	1.30	1.19	1.26	1.21	1.46	1.32	1.18	1.29	1.19	1.51	1.35	1.17	1.31
75 / 63	T.C.	23.1	24.6	24.5	28.3	30.5	25.9	26.0	25.7	30.0	32.1	28.7	27.4	26.8	31.7	33.7
	S.C.	23.1	24.6	17.2	18.2	14.4	25.9	26.0	19.8	21.1	16.0	28.6	27.3	22.3	24.0	17.6
	K.W.	1.38	1.56	1.56	1.35	1.53	1.37	1.62	1.62	1.34	1.58	1.35	1.67	1.67	1.33	1.64
85 / 69	T.C.	21.7	22.8	22.9	26.2	28.2	24.1	24.1	23.9	27.6	29.6	26.5	25.4	24.9	29.0	31.0
	S.C.	21.7	22.8	16.4	17.0	13.6	24.1	24.1	18.9	19.8	15.1	26.4	25.4	21.5	22.5	16.6
	K.W.	1.55	1.74	1.74	1.63	1.67	1.54	1.80	1.80	1.66	1.75	1.54	1.86	1.86	1.69	1.83
95 / 75	T.C.	20.3	21.0	21.3	24.0	26.0	22.3	22.2	22.1	25.1	27.2	24.3	23.5	22.9	26.2	28.4
	S.C.	20.3	21.0	15.6	15.8	12.8	22.3	22.2	18.1	18.4	14.2	24.2	23.4	20.6	21.0	15.6
	K.W.	1.73	1.92	1.92	1.91	1.82	1.72	1.99	1.98	1.98	1.93	1.72	2.05	2.04	2.04	2.03
105 / 83	T.C.	18.6	19.0	19.1	21.7	23.6	20.0	20.0	19.6	22.5	24.5	21.5	21.1	20.2	23.3	25.4
	S.C.	18.5	19.0	14.6	14.8	11.8	20.0	20.0	16.6	17.3	13.1	21.5	21.0	18.7	19.8	14.5
	K.W.	1.97	2.10	2.10	2.09	2.03	1.97	2.14	2.14	2.13	2.10	1.97	2.19	2.18	2.17	2.17
115 / 89	T.C.	16.9	17.1	17.0	19.5	21.4	17.8	17.9	17.3	20.0	21.9	18.8	18.7	17.6	20.5	22.5
	S.C.	16.8	17.0	13.6	13.9	10.8	17.8	17.9	15.2	16.3	12.1	18.8	18.7	16.8	18.7	13.4
	K.W.	2.21	2.28	2.27	2.27	2.23	2.21	2.30	2.29	2.29	2.26	2.21	2.32	2.31	2.30	2.30
125 / 95	T.C.	15.1	15.1	14.8	17.3	19.1	15.6	15.7	14.9	17.4	19.4	16.1	16.4	14.9	17.6	19.6
	S.C.	15.1	15.1	12.7	12.9	9.8	15.6	15.7	13.8	15.3	11.0	16.1	16.3	14.9	17.6	12.3
	K.W.	2.45	2.45	2.45	2.45	2.43	2.45	2.45	2.45	2.44	2.43	2.46	2.45	2.45	2.44	2.43

COOLING PERFORMANCE DATA - 2.5 TON																
PACKAGED UNIT MODEL NO.		PHG4A30														
CONDENSER ENTERING AIR TEMPERATURE (°F)	ID CFM	800					1000					1200				
		80	80	75	80	80	80	80	75	80	80	80	80	75	80	80
		57	62	62	67	72	57	62	62	67	72	57	62	62	67	72
55 / 45	T.C.	31.6	35.2	33.6	38.4	41.5	34.0	37.9	36.1	40.1	42.7	36.5	40.7	38.5	41.9	47.9
	S.C.	30.7	28.4	23.1	23.0	19.6	33.1	32.3	26.1	24.0	21.3	35.5	36.2	29.0	28.6	23.0
	K.W.	1.46	1.44	1.44	1.42	1.41	1.51	1.50	1.50	1.48	1.47	1.56	1.56	1.56	1.54	1.54
65 / 55	T.C.	29.6	31.9	32.2	35.4	40.0	32.0	34.3	34.7	37.6	42.6	34.5	36.7	37.1	39.7	47.1
	S.C.	28.8	26.8	22.5	22.3	18.8	31.2	30.4	25.5	24.1	20.5	33.5	34.0	28.5	27.9	22.2
	K.W.	1.63	1.61	1.61	1.60	1.58	1.68	1.67	1.67	1.66	1.64	1.73	1.73	1.73	1.72	1.71
75 / 63	T.C.	27.6	28.6	30.9	32.4	38.5	30.0	30.6	33.3	35.0	42.5	32.4	32.7	35.7	37.6	46.6
	S.C.	26.9	25.3	21.9	21.3	18.0	29.2	28.6	24.9	24.2	19.7	31.5	31.8	27.9	27.1	21.4
	K.W.	1.80	1.78	1.78	1.77	1.76	1.85	1.84	1.85	1.83	1.82	1.91	1.90	1.91	1.89	1.88
85 / 69	T.C.	26.4	27.2	27.8	29.8	36.1	28.3	29.3	29.9	32.2	39.2	30.3	31.4	31.9	34.6	42.3
	S.C.	25.7	24.8	20.5	20.4	17.0	27.6	27.7	23.4	23.3	18.7	29.5	30.6	26.3	26.2	20.4
	K.W.	1.98	1.97	1.97	1.97	1.96	2.04	2.03	2.04	2.03	2.03	2.10	2.10	2.10	2.09	2.09
95 / 75	T.C.	25.2	25.9	24.7	27.2	33.7	26.7	28.0	26.4	29.4	35.9	28.1	30.1	28.1	31.7	38.1
	S.C.	24.6	24.3	19.1	19.5	16.0	26.0	26.8	21.9	22.4	17.7	27.4	29.3	24.7	25.2	19.3
	K.W.	2.16	2.16	2.16	2.16	2.17	2.23	2.22	2.22	2.23	2.24	2.30	2.29	2.29	2.29	2.31
105 / 83	T.C.	22.7	23.8	22.5	25.3	30.2	23.9	25.5	23.7	27.2	32.3	25.1	27.2	24.8	29.0	34.4
	S.C.	22.1	22.5	17.9	18.3	14.4	23.3	24.5	20.1	21.0	15.8	24.5	26.5	22.4	23.7	17.2
	K.W.	2.40	2.40	2.40	2.40	2.41	2.47	2.47	2.47	2.47	2.48	2.54	2.54	2.53	2.54	2.55
115 / 89	T.C.	20.3	21.7	20.3	23.4	26.8	21.3	23.1	21.0	24.9	28.8	22.2	24.4	21.6	26.4	30.9
	S.C.	19.8	20.9	16.8	17.2	12.9	20.7	22.3	18.5	19.7	14.0	21.7	23.7	20.1	22.3	15.2
	K.W.	2.64	2.64	2.63	2.64	2.65	2.71	2.71	2.70	2.71	2.72	2.77	2.78	2.77	2.78	2.79
125 / 95	T.C.	17.9	19.7	18.2	21.5	23.4	18.6	20.6	18.3	22.7	25.3	19.3	21.5	18.4	23.9	27.3
	S.C.	17.5	19.2	15.6	16.1	11.3	18.1	20.1	16.8	18.4	12.2	18.8	20.9	17.9	20.8	13.2
	K.W.	2.87	2.88	2.87	2.87	2.89	2.94	2.95	2.94	2.95	2.96	3.01	3.02	3.01	3.02	3.03

COOLING PERFORMANCE DATA - 3 TON																
PACKAGED UNIT MODEL NO.		PHG4B36														
CONDENSER ENTERING AIR TEMPERATURE (°F)	ID CFM	1000					1200					1400				
	IDDB	80	80	75	80	80	80	80	75	80	80	80	80	80	80	80
	IDWB	57	62	62	67	72	57	62	62	67	72	57	62	62	67	72
55 / 45	T.C.	38.8	41.2	39.8	45.3	48.0	42.0	43.4	42.0	47.1	49.8	45.2	45.6	44.2	49.0	51.7
	S.C.	37.2	34.3	28.1	28.8	22.5	40.3	38.3	31.3	31.1	24.4	43.4	42.2	34.5	33.4	26.3
	K.W.	1.80	1.80	1.81	1.79	1.78	1.86	1.87	1.87	1.85	1.84	1.92	1.93	1.93	1.91	1.91
65 / 55	T.C.	36.3	38.4	37.8	42.4	45.9	39.4	40.5	40.2	44.1	48.3	42.5	42.7	42.6	45.9	50.7
	S.C.	34.9	32.8	27.4	27.7	22.6	37.9	36.4	30.6	30.3	24.4	41.0	40.1	33.7	32.9	26.3
	K.W.	2.00	2.00	2.01	1.99	1.98	2.06	2.06	2.07	2.05	2.04	2.13	2.13	2.13	2.11	2.11
75 / 63	T.C.	33.8	35.6	35.8	39.5	43.8	36.8	37.6	38.5	41.1	46.7	39.7	39.7	41.1	42.8	49.7
	S.C.	32.6	31.2	26.7	26.6	22.6	35.5	34.6	29.8	29.5	24.5	38.5	38.0	33.0	32.4	26.3
	K.W.	2.21	2.20	2.21	2.20	2.18	2.27	2.26	2.27	2.26	2.24	2.33	2.32	2.34	2.32	2.31
85 / 69	T.C.	32.7	33.7	33.2	37.3	41.6	35.2	35.5	36.6	38.8	44.0	37.8	37.3	40.0	40.4	46.3
	S.C.	31.7	30.5	25.3	25.6	21.2	34.4	33.4	28.3	28.6	23.0	37.0	36.4	31.3	31.5	24.8
	K.W.	2.44	2.44	2.44	2.44	2.43	2.51	2.51	2.51	2.50	2.50	2.57	2.57	2.58	2.56	2.56
95 / 75	T.C.	31.5	31.9	30.6	35.0	39.5	33.7	33.4	34.7	36.5	41.2	35.8	34.9	38.9	38.0	43.0
	S.C.	30.9	29.8	23.9	24.7	19.7	33.2	32.3	26.8	27.7	21.5	35.6	34.9	29.6	30.7	23.4
	K.W.	2.68	2.68	2.68	2.68	2.68	2.75	2.75	2.75	2.74	2.75	2.82	2.82	2.82	2.81	2.81
105 / 83	T.C.	28.5	28.6	27.1	31.5	35.6	30.2	29.9	29.8	32.5	36.6	31.8	31.2	32.6	33.4	37.6
	S.C.	28.1	27.2	22.3	23.2	18.2	29.9	29.2	24.3	25.9	19.6	31.7	31.2	26.4	28.6	21.1
	K.W.	2.99	2.99	2.99	2.99	3.00	3.06	3.06	3.06	3.06	3.07	3.13	3.13	3.13	3.13	3.14
115 / 89	T.C.	25.6	25.4	23.7	28.1	31.9	26.8	26.5	25.1	28.6	32.2	28.0	27.6	26.5	29.0	32.4
	S.C.	25.4	24.7	20.6	21.7	16.7	26.7	26.2	22.0	24.1	17.8	27.9	27.6	23.4	26.6	18.9
	K.W.	3.29	3.29	3.29	3.30	3.31	3.36	3.36	3.36	3.37	3.38	3.43	3.44	3.43	3.44	3.45
125 / 95	T.C.	22.7	22.2	20.3	24.6	28.2	23.4	23.1	20.3	24.6	27.7	24.1	24.0	20.3	24.6	27.3
	S.C.	22.7	22.2	19.0	20.2	15.3	23.4	23.1	19.7	22.4	16.0	24.1	24.0	20.3	24.6	16.7
	K.W.	3.59	3.59	3.59	3.61	3.62	3.66	3.67	3.66	3.68	3.69	3.74	3.74	3.73	3.75	3.76

COOLING PERFORMANCE DATA - 3.5 TON																
PACKAGED UNIT MODEL NO.		PHG4B42														
CONDENSER ENTERING AIR TEMPERATURE (°F)	ID CFM	1200					1400					1600				
	IDDB	80	80	75	80	80	80	80	75	80	80	80	80	75	80	80
	IDWB	57	62	62	67	72	57	62	62	67	72	57	62	62	67	72
55 / 45	T.C.	47.9	50.7	50.8	59.4	62.8	50.5	52.8	52.6	59.8	64.5	53.0	55.0	54.3	60.3	67.4
	S.C.	46.4	42.1	36.6	37.7	30.5	48.7	45.9	39.4	40.3	32.3	51.1	49.6	42.1	43.0	34.0
	K.W.	2.11	2.10	2.10	2.07	2.05	2.16	2.16	2.16	2.13	2.11	2.21	2.22	2.22	2.19	2.17
65 / 55	T.C.	45.0	46.8	47.0	54.7	59.5	47.3	48.8	48.7	56.3	63.0	49.6	50.8	50.3	58.0	67.0
	S.C.	43.9	39.9	34.4	35.9	29.1	46.1	43.3	37.1	38.7	31.1	48.3	46.7	39.8	41.5	33.1
	K.W.	2.37	2.36	2.36	2.34	2.31	2.42	2.42	2.42	2.40	2.37	2.48	2.48	2.48	2.46	2.44
75 / 63	T.C.	42.1	43.0	43.2	50.0	56.1	44.2	44.8	44.8	52.9	61.4	46.2	46.6	46.4	55.8	66.7
	S.C.	41.4	37.7	32.2	34.1	27.8	43.5	40.8	34.9	37.0	29.9	45.5	43.9	37.5	39.9	32.1
	K.W.	2.62	2.61	2.61	2.60	2.57	2.68	2.67	2.68	2.66	2.64	2.74	2.74	2.74	2.73	2.71
85 / 69	T.C.	39.4	39.6	39.9	46.3	51.9	41.4	41.2	41.2	48.4	55.3	43.4	42.7	42.5	50.5	58.7
	S.C.	38.8	36.0	30.6	32.2	25.7	40.8	38.6	33.0	35.0	27.7	42.8	41.1	35.5	37.8	29.7
	K.W.	2.89	2.89	2.89	2.89	2.88	2.96	2.96	2.96	2.96	2.95	3.03	3.03	3.03	3.02	3.02
95 / 75	T.C.	36.6	36.3	36.6	42.7	47.7	38.6	37.6	37.6	44.0	49.2	40.5	38.8	38.5	45.3	50.6
	S.C.	36.2	34.3	28.9	30.3	23.7	38.1	36.4	31.2	33.0	25.5	40.0	38.4	33.4	35.6	27.3
	K.W.	3.17	3.17	3.17	3.18	3.19	3.24	3.25	3.24	3.25	3.25	3.31	3.32	3.31	3.32	3.32
105 / 83	T.C.	33.2	33.3	32.7	38.4	43.4	34.7	34.3	33.4	39.2	44.5	36.2	35.4	34.2	40.1	45.6
	S.C.	32.8	31.9	27.3	28.4	22.1	34.3	33.4	29.0	30.9	23.9	35.8	35.0	30.7	33.3	25.6
	K.W.	3.53	3.53	3.53	3.54	3.55	3.61	3.60	3.60	3.61	3.62	3.68	3.68	3.67	3.68	3.69
115 / 89	T.C.	29.9	30.4	28.9	34.1	39.3	31.0	31.2	29.4	34.6	40.0	32.1	32.0	29.9	35.0	40.7
	S.C.	29.5	29.6	25.7	26.6	20.6	30.6	30.6	26.8	28.8	22.3	31.7	31.7	28.0	31.0	24.0
	K.W.	3.88	3.88	3.87	3.89	3.90	3.96	3.95	3.94	3.96	3.97	4.04	4.03	4.02	4.03	4.04
125 / 95	T.C.	26.6	27.5	25.1	29.9	35.2	27.2	28.1	25.4	30.0	35.5	27.9	28.7	25.7	30.0	35.9
	S.C.	26.3	27.2	24.0	24.8	19.1	26.9	27.8	24.7	26.8	20.7	27.6	28.3	25.4	28.8	22.3
	K.W.	4.23	4.23	4.21	4.24	4.26	4.31	4.30	4.29	4.31	4.33	4.40	4.38	4.36	4.38	4.40

COOLING PERFORMANCE DATA - 4 TON																
PACKAGED UNIT MODEL NO.		PHG4B48														
CONDENSER ENTERING AIR TEMPERATURE (°F)	ID CFM	1300					1500					1700				
		IDDB	80	80	75	80	80	80	80	75	80	80	80	80	75	80
	IDWB	57	62	62	67	72	57	62	62	67	72	57	62	62	67	72
55 / 45	T.C.	49.8	53.9	53.6	58.9	60.3	52.3	55.4	55.0	59.6	60.7	54.9	56.8	56.5	60.3	61.0
	S.C.	49.4	45.8	39.1	39.5	36.7	52.3	48.7	41.7	42.1	39.6	54.9	51.7	44.3	44.6	42.5
	K.W.	2.48	2.45	2.45	2.43	2.42	2.53	2.51	2.51	2.49	2.49	2.58	2.57	2.57	2.55	2.55
65 / 55	T.C.	47.8	50.7	50.8	56.4	58.1	50.4	52.2	52.3	57.3	59.0	52.9	53.8	53.7	58.3	59.9
	S.C.	47.8	43.7	37.4	38.0	35.0	50.4	46.6	39.9	40.8	37.3	52.9	49.5	42.4	43.6	39.6
	K.W.	2.74	2.73	2.73	2.72	2.72	2.80	2.79	2.80	2.79	2.78	2.86	2.86	2.86	2.85	2.85
75 / 63	T.C.	45.9	47.5	48.1	53.9	56.0	48.4	49.1	49.5	55.1	57.3	51.0	50.8	51.0	56.3	58.7
	S.C.	45.9	41.6	35.7	36.6	33.2	48.4	44.5	38.1	39.5	35.0	51.0	47.3	40.6	42.5	36.7
	K.W.	3.00	3.01	3.01	3.01	3.01	3.07	3.08	3.08	3.08	3.08	3.14	3.15	3.15	3.15	3.15
85 / 69	T.C.	43.4	44.6	45.1	50.6	53.5	45.2	45.9	46.4	51.9	54.6	46.9	47.2	47.6	53.1	55.8
	S.C.	43.4	40.3	34.0	35.1	32.6	45.2	43.0	36.4	37.7	34.4	46.9	45.6	38.8	40.4	36.1
	K.W.	3.31	3.31	3.32	3.34	3.11	3.23	3.38	3.39	3.41	3.15	3.16	3.46	3.47	3.48	3.19
95 / 75	T.C.	40.9	41.8	42.2	47.3	51.0	41.9	42.7	43.3	48.6	51.9	42.8	43.6	44.3	49.9	52.9
	S.C.	40.9	39.0	32.4	33.6	32.0	41.9	41.5	34.7	36.0	33.8	42.8	43.6	37.0	38.3	35.5
	K.W.	3.61	3.62	3.64	3.66	3.21	3.39	3.69	3.71	3.73	3.22	3.18	3.77	3.78	3.81	3.23
105 / 83	T.C.	37.4	38.0	37.4	42.6	46.2	38.0	38.5	38.1	43.6	47.1	38.5	39.0	38.9	44.6	48.1
	S.C.	37.4	36.2	30.1	31.2	29.1	38.0	37.8	32.1	33.4	30.8	38.5	39.0	34.1	35.7	32.4
	K.W.	3.87	3.88	4.05	4.07	3.78	3.73	3.93	4.12	4.14	3.81	3.59	3.98	4.20	4.22	3.84
115 / 89	T.C.	34.0	34.3	32.7	38.0	41.5	34.1	34.4	33.1	38.7	42.5	34.3	34.5	33.6	39.4	43.4
	S.C.	34.0	33.5	27.9	28.8	26.4	34.1	34.2	29.6	31.0	27.9	34.3	34.5	31.3	33.1	29.4
	K.W.	4.13	4.13	4.44	4.46	4.33	4.06	4.16	4.52	4.54	4.39	3.99	4.19	4.59	4.62	4.44
125 / 95	T.C.	30.6	30.6	28.0	33.5	36.9	30.3	30.3	28.1	33.8	37.8	30.1	30.1	28.3	34.1	38.7
	S.C.	30.6	30.6	25.6	26.5	23.6	30.3	30.3	27.1	28.5	25.0	30.1	30.1	28.3	30.5	26.5
	K.W.	4.38	4.38	4.84	4.86	4.88	4.39	4.39	4.92	4.94	4.96	4.39	4.39	4.99	5.01	5.04

COOLING PERFORMANCE DATA - 5 TON																
PACKAGED UNIT MODEL NO.		PHG4B60														
CONDENSER ENTERING AIR TEMPERATURE (°F)	ID CFM	1600					1800					2000				
		IDDB	80	80	75	80	80	80	75	80	80	80	80	75	80	80
	IDWB	57	62	62	67	72	57	62	62	67	72	57	62	62	67	72
55 / 45	T.C.	65.6	69.4	68.1	73.1	72.9	69.0	71.4	70.3	74.5	74.5	72.5	73.5	72.5	75.8	76.0
	S.C.	64.3	58.0	48.1	47.3	37.1	67.0	62.4	51.6	49.8	41.1	69.7	66.8	55.0	52.3	45.0
	K.W.	3.18	3.16	3.15	3.15	3.13	3.28	3.26	3.24	3.24	3.24	3.37	3.36	3.34	3.34	3.34
65 / 55	T.C.	61.4	64.7	64.3	69.9	72.4	65.0	67.0	66.8	71.5	74.0	68.6	69.2	69.3	73.1	75.6
	S.C.	60.1	55.3	46.5	46.0	36.8	63.3	59.9	50.1	49.0	39.5	66.5	64.5	53.7	51.9	42.2
	K.W.	3.51	3.50	3.50	3.51	3.51	3.61	3.60	3.59	3.60	3.61	3.71	3.69	3.69	3.70	3.70
75 / 63	T.C.	57.2	60.1	60.4	66.8	72.0	61.0	62.6	63.3	68.6	73.6	64.7	65.0	66.1	70.4	75.3
	S.C.	55.9	52.6	44.8	44.8	36.5	59.6	57.4	48.6	48.2	38.0	63.4	62.2	52.3	51.6	39.5
	K.W.	3.84	3.84	3.85	3.87	3.88	3.95	3.93	3.94	3.97	3.97	4.05	4.03	4.04	4.06	4.07
85 / 69	T.C.	54.8	56.9	56.1	62.3	67.7	58.2	59.1	58.2	64.1	69.1	61.5	61.2	60.4	65.9	70.4
	S.C.	54.0	51.4	42.5	42.6	33.5	57.5	55.6	46.1	46.2	35.6	61.0	59.9	49.7	49.7	37.6
	K.W.	4.24	4.24	4.24	4.26	4.29	4.34	4.33	4.33	4.36	4.39	4.45	4.43	4.43	4.46	4.48
95 / 75	T.C.	52.4	53.8	51.7	57.8	63.4	55.4	55.6	53.2	59.6	64.5	58.4	57.4	54.6	61.4	65.6
	S.C.	52.2	50.1	40.1	40.4	30.6	55.4	53.9	43.5	44.1	33.2	58.4	57.4	47.0	47.8	35.8
	K.W.	4.63	4.63	4.63	4.66	4.71	4.73	4.73	4.73	4.76	4.80	4.84	4.83	4.83	4.86	4.90
105 / 83	T.C.	48.2	48.8	46.6	52.5	57.4	50.5	50.7	47.8	53.6	58.1	52.9	52.6	49.1	54.8	58.8
	S.C.	48.1	46.5	37.6	38.1	28.8	50.5	49.7	40.9	41.6	31.0	52.9	52.6	44.2	45.0	33.3
	K.W.	5.15	5.15	5.14	5.18	5.23	5.26	5.26	5.25	5.28	5.33	5.37	5.36	5.35	5.39	5.42
115 / 89	T.C.	44.1	44.1	41.5	47.3	51.6	45.8	46.0	42.7	47.8	52.0	47.6	47.9	43.8	48.4	52.3
	S.C.	44.1	43.0	35.2	35.9	27.0	45.8	45.6	38.3	39.1	28.9	47.6	47.9	41.4	42.3	30.7
	K.W.	5.66	5.65	5.64	5.69	5.74	5.77	5.77	5.75	5.79	5.83	5.88	5.88	5.86	5.89	5.93
125 / 95	T.C.	40.0	39.3	36.5	42.0	45.8	41.2	41.3	37.5	42.0	45.8	42.4	43.3	38.4	42.0	45.7
	S.C.	40.0	39.3	32.8	33.7	25.3	41.2	41.3	35.8	36.7	26.8	42.4	43.3	38.4	39.6	28.2
	K.W.	6.17	6.16	6.14	6.20	6.24	6.28	6.28	6.25	6.30	6.34	6.39	6.39	6.37	6.40	6.44

HEATING PERFORMANCE DATA - 2 TON										
PACKAGED UNIT MODEL NO		PHG4A24								
AIR TEMPERATURE ENTERING OUTDOOR UNIT (°F)	AIR TEMPERATURE ENTERING INDOOR COIL (°F)	ID CFM								
		600			800			1000		
		MBH	COP	kW	MBH	COP	kW	MBH	COP	kW
60	60	29.1	4.08	2.09	29.9	4.50	1.95	30.8	4.80	1.88
	70	27.9	3.56	2.30	28.5	4.40	1.90	28.6	4.07	2.06
	80	26.6	3.11	2.51	27.1	4.27	1.86	26.4	3.44	2.25
47	60	24.3	3.54	2.01	24.6	3.81	1.89	25.1	3.98	1.85
	70	23.3	3.10	2.20	23.6	3.74	1.85	24.0	3.45	2.04
	80	22.3	2.72	2.40	22.5	3.64	1.81	22.8	3.00	2.23
40	60	22.0	3.29	1.96	22.2	3.48	1.87	22.7	3.60	1.85
	70	20.9	2.84	2.16	21.1	3.40	1.82	21.4	3.09	2.03
	80	19.8	2.47	2.35	20.0	3.29	1.78	20.2	2.69	2.20
30	60	18.1	2.81	1.89	18.6	2.98	1.83	18.8	3.03	1.82
	70	15.8	2.28	2.03	16.1	2.65	1.78	17.8	2.62	1.99
	80	13.5	1.81	2.18	13.6	2.29	1.74	16.7	2.26	2.17
17	60	13.7	2.22	1.81	14.4	2.37	1.78	14.3	2.35	1.79
	70	12.7	1.87	1.99	13.4	2.26	1.74	13.2	1.98	1.95
	80	11.7	1.58	2.17	12.3	2.12	1.70	12.1	1.67	2.12
10	60	11.7	1.94	1.77	12.1	2.03	1.75	11.8	1.95	1.77
	70	10.7	1.60	1.96	11.0	1.69	1.91	10.8	1.64	1.93
	80	9.8	1.34	2.14	9.9	1.40	2.07	9.9	1.39	2.08

HEATING PERFORMANCE DATA - 2.5 TON										
PACKAGED UNIT MODEL NO		PHG4A30								
AIR TEMPERATURE ENTERING OUTDOOR UNIT (°F)	AIR TEMPERATURE ENTERING INDOOR COIL (°F)	ID CFM								
		800			1000			1200		
		MBH	COP	kW	MBH	COP	kW	MBH	COP	kW
60	60	34.4	4.63	2.18	36.8	5.04	2.14	39.2	5.47	2.10
	70	32.8	4.04	2.38	34.5	4.34	2.33	36.1	4.64	2.28
	80	31.2	3.53	2.59	32.1	3.73	2.52	33.0	3.93	2.46
47	60	28.1	3.94	2.09	29.6	4.19	2.07	31.0	4.45	2.04
	70	26.9	3.46	2.28	28.1	3.66	2.25	29.3	3.89	2.21
	80	25.6	3.04	2.47	26.6	3.22	2.42	27.5	3.39	2.38
40	60	25.1	3.59	2.05	26.1	3.77	2.03	27.2	3.97	2.01
	70	23.9	3.16	2.22	24.9	3.32	2.20	25.9	3.48	2.18
	80	22.7	2.77	2.40	23.7	2.93	2.37	24.6	3.08	2.34
30	60	21.0	3.11	1.98	21.6	3.20	1.98	22.3	3.31	1.97
	70	19.9	2.71	2.15	20.6	2.82	2.14	21.4	2.94	2.13
	80	18.7	2.37	2.31	19.6	2.50	2.30	20.5	2.62	2.29
17	60	16.3	2.51	1.90	16.7	2.56	1.91	17.0	2.60	1.92
	70	15.1	2.17	2.04	15.6	2.23	2.05	16.1	2.28	2.07
	80	13.9	1.86	2.19	14.5	1.93	2.20	15.2	2.02	2.21
10	60	14.1	2.23	1.85	14.4	2.26	1.87	14.7	2.28	1.89
	70	12.7	1.87	1.99	13.1	1.91	2.01	13.5	1.95	2.03
	80	11.4	1.58	2.12	11.9	1.62	2.15	12.4	1.67	2.17

HEATING PERFORMANCE DATA - 3 TON										
PACKAGED UNIT MODEL NO		PHG4B36								
AIR TEMPERATURE ENTERING OUTDOOR UNIT (°F)	AIR TEMPERATURE ENTERING INDOOR COIL (°F)	ID CFM								
		1000			1200			1400		
		MBH	COP	kW	MBH	COP	kW	MBH	COP	kW
60	60	43.0	4.69	2.69	44.6	4.95	2.64	46.1	5.22	2.59
	70	40.2	3.97	2.97	41.9	4.22	2.91	43.7	4.50	2.85
	80	37.3	3.36	3.25	39.3	3.62	3.18	41.3	3.89	3.11
47	60	34.1	3.87	2.58	35.8	4.11	2.55	37.4	4.33	2.53
	70	33.0	3.42	2.83	34.6	3.62	2.80	36.2	3.84	2.76
	80	31.9	3.03	3.09	33.4	3.22	3.04	34.9	3.41	3.00
40	60	30.0	3.49	2.52	31.6	3.69	2.51	33.2	3.91	2.49
	70	29.5	3.13	2.76	30.9	3.31	2.74	32.4	3.49	2.72
	80	29.0	2.83	3.00	30.2	2.98	2.97	31.5	3.14	2.94
30	60	25.0	3.00	2.44	26.4	3.17	2.44	27.8	3.34	2.44
	70	24.8	2.74	2.65	26.0	2.88	2.65	28.0	3.10	2.65
	80	24.7	2.52	2.87	25.6	2.62	2.86	26.0	2.66	2.86
17	60	19.9	2.50	2.33	20.9	2.61	2.35	21.9	2.69	2.38
	70	19.4	2.26	2.52	20.2	2.33	2.54	21.0	2.39	2.57
	80	18.9	2.05	2.70	19.6	2.10	2.73	20.2	2.15	2.75
10	60	17.9	2.31	2.27	18.5	2.35	2.31	19.1	2.39	2.34
	70	16.9	2.03	2.44	17.4	2.06	2.48	18.0	2.09	2.52
	80	15.8	1.77	2.61	16.3	1.80	2.65	16.8	1.83	2.69

HEATING PERFORMANCE DATA - 3.5 TON										
PACKAGED UNIT MODEL NO		PHG4B42								
AIR TEMPERATURE ENTERING OUTDOOR UNIT (°F)	AIR TEMPERATURE ENTERING INDOOR COIL (°F)	ID CFM								
		1200			1400			1600		
		MBH	COP	kW	MBH	COP	kW	MBH	COP	kW
60	60	51.1	4.88	3.07	52.7	5.08	3.04	54.3	5.29	3.01
	70	48.9	4.32	3.32	50.2	4.46	3.30	51.6	4.60	3.29
	80	46.7	3.84	3.56	47.8	3.94	3.56	48.9	4.01	3.57
47	60	39.2	3.91	2.94	40.5	4.07	2.92	41.8	4.21	2.91
	70	37.6	3.47	3.18	39.2	3.61	3.18	40.8	3.76	3.18
	80	36.0	3.09	3.42	37.9	3.23	3.44	39.8	3.38	3.45
40	60	33.9	3.46	2.87	34.9	3.58	2.86	36.0	3.70	2.85
	70	32.6	3.07	3.11	34.0	3.20	3.11	35.5	3.33	3.12
	80	31.2	2.73	3.35	33.2	2.89	3.37	35.1	3.04	3.38
30	60	27.5	2.92	2.76	28.1	2.97	2.77	28.7	3.03	2.78
	70	26.4	2.58	3.00	27.6	2.68	3.02	28.0	2.71	3.03
	80	25.4	2.30	3.24	27.1	2.43	3.27	26.0	2.32	3.29
17	60	21.4	2.38	2.63	21.3	2.36	2.65	21.2	2.32	2.68
	70	20.6	2.11	2.86	20.8	2.11	2.89	21.1	2.11	2.93
	80	19.8	1.87	3.10	20.4	1.90	3.14	20.9	1.93	3.17
10	60	19.1	2.19	2.56	18.6	2.10	2.59	18.1	2.02	2.62
	70	18.4	1.93	2.79	18.0	1.86	2.83	17.5	1.79	2.87
	80	17.7	1.72	3.02	17.3	1.65	3.07	17.0	1.60	3.11

HEATING PERFORMANCE DATA - 4 TON										
PACKAGED UNIT MODEL NO		PHG4B48								
AIR TEMPERATURE ENTERING OUTDOOR UNIT (°F)	AIR TEMPERATURE ENTERING INDOOR COIL (°F)	ID CFM								
		1300			1500			1700		
		MBH	COP	kW	MBH	COP	kW	MBH	COP	kW
60	60	59.8	4.77	3.68	60.1	5.02	3.51	60.4	5.30	3.34
	70	57.2	4.07	4.12	57.8	4.30	3.94	58.4	4.55	3.76
	80	54.6	3.50	4.57	55.5	3.72	4.37	56.5	3.96	4.18
47	60	48.6	4.05	3.52	49.2	4.27	3.38	49.8	4.52	3.23
	70	46.4	3.45	3.94	47.0	3.64	3.78	47.6	3.84	3.63
	80	44.2	2.98	4.35	44.8	3.13	4.19	45.4	3.31	4.02
40	60	43.1	3.67	3.44	43.8	3.88	3.31	44.5	4.10	3.18
	70	41.0	3.14	3.83	41.6	3.30	3.70	42.1	3.47	3.56
	80	39.0	2.70	4.23	39.4	2.82	4.09	39.8	2.96	3.94
30	60	35.7	3.16	3.31	36.5	3.34	3.20	37.3	3.54	3.09
	70	33.9	2.69	3.69	34.4	2.82	3.57	34.9	2.96	3.46
	80	32.1	2.32	4.06	32.3	2.40	3.94	32.5	2.49	3.82
17	60	27.2	2.53	3.15	27.9	2.66	3.07	28.6	2.80	2.99
	70	26.8	2.24	3.50	27.4	2.35	3.41	27.8	2.45	3.33
	80	23.8	1.82	3.84	23.9	1.86	3.76	24.0	1.92	3.67
10	60	23.1	2.21	3.07	23.7	2.32	3.00	24.4	2.44	2.93
	70	21.4	1.84	3.40	21.8	1.92	3.33	22.1	1.99	3.26
	80	19.8	1.56	3.72	19.8	1.59	3.66	19.9	1.62	3.59

HEATING PERFORMANCE DATA - 5 TON										
PACKAGED UNIT MODEL NO		PHG4B60								
AIR TEMPERATURE ENTERING OUTDOOR UNIT (°F)	AIR TEMPERATURE ENTERING INDOOR COIL (°F)	ID CFM								
		1600			1800			2000		
		MBH	COP	kW	MBH	COP	kW	MBH	COP	kW
60	60	71.8	4.84	4.35	72.1	4.96	4.26	72.3	5.10	4.16
	70	67.7	4.14	4.79	69.2	4.33	4.69	70.8	4.53	4.58
	80	63.5	3.56	5.23	67.0	3.84	5.12	70.4	4.13	5.00
47	60	56.4	3.96	4.17	57.4	4.09	4.11	58.3	4.22	4.05
	70	55.5	3.54	4.59	56.8	3.68	4.52	58.1	3.83	4.45
	80	54.5	3.19	5.01	56.2	3.34	4.93	57.9	3.50	4.85
40	60	49.8	3.59	4.07	51.0	3.71	4.03	52.2	3.84	3.98
	70	49.6	3.24	4.48	50.9	3.38	4.42	52.2	3.50	4.37
	80	49.3	2.95	4.89	50.7	3.08	4.82	52.1	3.21	4.76
30	60	42.2	3.15	3.93	43.4	3.25	3.91	44.5	3.35	3.89
	70	41.8	2.84	4.32	42.0	2.87	4.29	44.8	3.07	4.27
	80	41.5	2.58	4.71	41.0	2.57	4.68	45.1	2.85	4.64
17	60	35.8	2.80	3.75	36.0	2.81	3.76	36.3	2.82	3.77
	70	33.2	2.36	4.12	34.5	2.45	4.12	37.1	2.63	4.13
	80	30.6	2.00	4.48	34.3	2.24	4.49	37.9	2.47	4.49
10	60	32.3	2.59	3.65	32.4	2.58	3.68	32.6	2.58	3.71
	70	28.5	2.08	4.01	30.9	2.25	4.03	33.4	2.42	4.05
	80	24.7	1.66	4.36	29.4	1.97	4.38	34.1	2.27	4.40

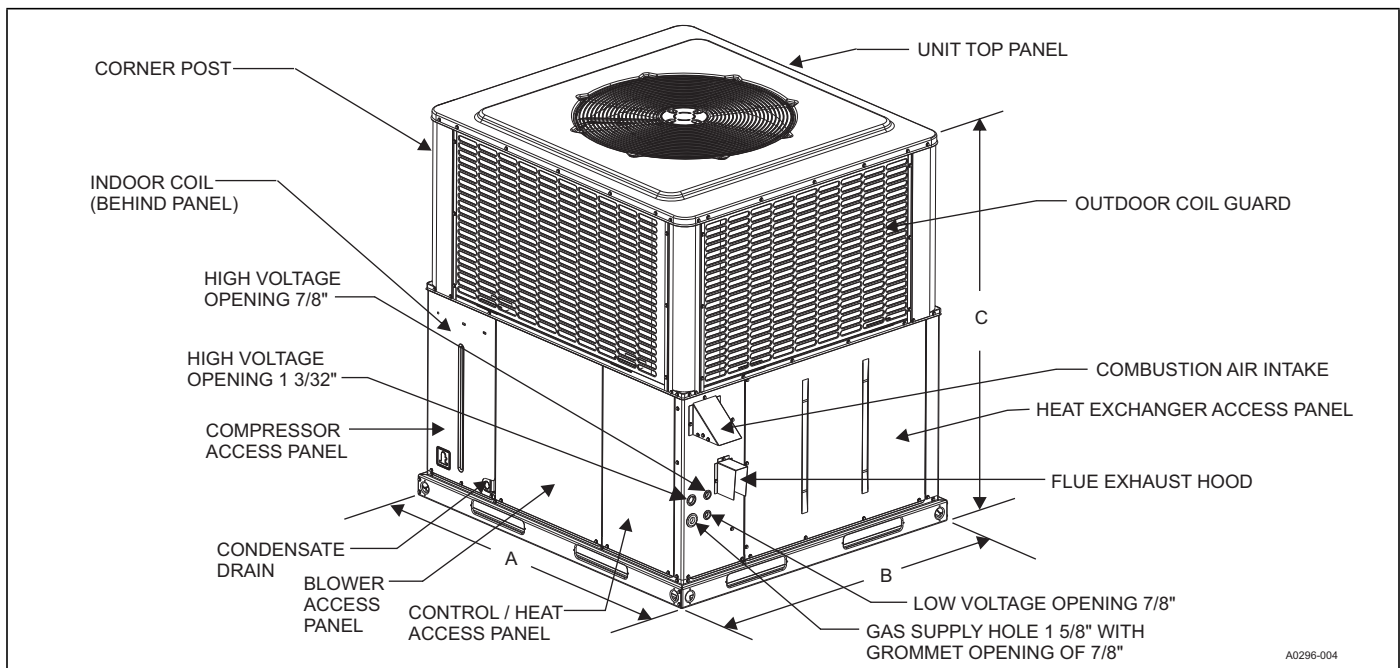

UNIT DIMENSIONS AND ACCESS LOCATIONS

Model	Dimensions (in.)		
	A	B	C
PHG4A24	51 1/4	35 3/4	44
PHG4A30	51 1/4	35 3/4	45
PHG4B36	51 1/4	45 3/4	47
PHG4B42	51 1/4	45 3/4	47
PHG4B48	51 1/4	45 3/4	53
PHG4B60	51 1/4	45 3/4	55

UNIT CLEARANCES^{1 2}

Direction	Distance (in.)	Direction	Distance (in.)
Top ³	36	Power Entry (Right Side)	36
Side Opposite Ducts	36	Left Side	24
Duct Panel	0	Bottom ⁴	1

1. Provide a 1-in. clearance between any combustible material and the supply air duct work.
2. Do not allow the products of combustion to accumulate within a confined space and recirculate.
3. Install units outdoors. Make sure that overhanging structures or shrubs do not obstruct the outdoor air discharge outlet.
4. You can install units on combustible materials made from wood or class A, B, or C roof covering materials if the factory base rails are left in place as shipped.

INDOOR BLOWER SPECIFICATIONS

Model	Motor				
	HP	RPM	Efficiency	SF	Frame
PHG4A24	1/2	Variable	0.8	1.0	48
PHG4A30	1/2	Variable	0.8	1.0	48
PHG4B36	1/2	Variable	0.8	1.0	48
PHG4B42	3/4	Variable	0.8	1.0	48
PHG4B48	3/4	Variable	0.8	1.0	48
PHG4B60	1	Variable	0.8	1.0	48

SOUND PERFORMANCE - COOLING

Model (ton)	Sound Rating ¹ dB(A)	Octave Band Centerline Frequency (Hz)						
		125	250	500	1000	2000	4000	8000
24	69.9	73.4	66.7	67.6	66.9	55.2	49.6	44.4
30	67.3	67.9	68.3	61.2	56.7	56.9	49.4	44.4
36	72.6	77.9	66.6	64.7	64.4	58.1	54.8	47.4
42	73.0	78.6	62.2	65.8	64.9	59.4	57.2	51.8
48	72.4	75.2	66.8	62.9	63.5	58.4	57.3	50.3
60	72.7	73.6	66.2	63.3	63.9	59.6	59.6	52.2

1. Rated in accordance with AHRI Standard 270.

SOUND PERFORMANCE - HEATING

Model (ton)	Sound Rating ¹ dB(A)	Octave Band Centerline Frequency (Hz)						
		125	250	500	1000	2000	4000	8000
24	71.0	73.8	67.0	68.1	67.7	56.7	49.9	45.3
30	68.3	68.3	68.9	62.6	57.6	57.1	49.6	45.1
36	73.7	78.1	67.2	66.1	65.4	58.3	54.8	48.7
42	74.5	80.5	62.7	67.3	66.6	59.2	61.4	50.7
48	73.8	72.4	67.4	63.4	64.8	60.4	59.5	55.2
60	74.1	74.9	66.3	65.1	65.5	59.6	59.5	52.8

1. Rated in accordance with AHRI Standard 270.

ELECTRICAL DATA - PHG4

Model	Voltage	Compressor			Outdoor Fan Motor	Indoor Blower Motor	MCA ¹ (A)	Max Fuse ² / Breaker ³ Size (A)
		RLA	LRA	MCC	FLA	FLA		
24075	208/230-1-60	10.8	55.0	16.8	1.3	2.6	17.4	25
30075	208/230-1-60	12.3	63.0	19.2	1.3	2.6	19.3	30
36100	208/230-1-60	14.7	75.0	22.9	1.7	3.8	23.9	35
42065, 42100	208/230-1-60	15.9	112.3	24.8	1.7	5.4	27.0	40
48100, 48125	208/230-1-60	18.3	108.0	28.5	1.7	5.4	30.0	45
60125	208/230-1-60	22.2	127.9	34.7	1.7	7.0	36.5	50

1. Minimum circuit ampacity.

2. Maximum overcurrent protection per standard UL 1995.

3. Fuse or HACR circuit breaker is field installed.

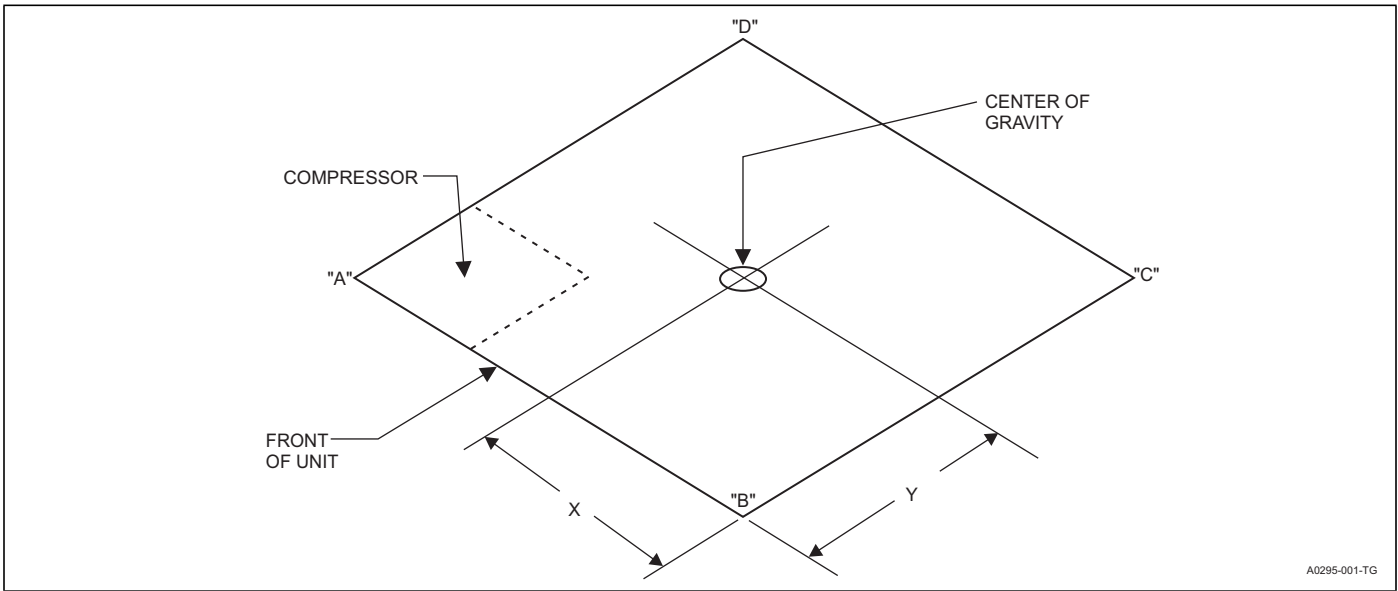

WEIGHTS AND DIMENSIONS

Model	Weight (lb)		Center of Gravity		4-Point Load Location (lb)			
	Shipping	Operating	X	Y	A	B	C	D
PHG4A240752X4	362	357	28	21	118	89	75	75
PHG4A300752X4	421	416	29	21	150	96	83	87
PHG4B361002X4	482	477	28	27	167	114	105	91
PHG4B420652X4	502	497	28	28	177	124	104	92
PHG4B421002X4	504	499	28	28	180	125	100	94
PHG4B481002X4	547	542	28	28	190	136	114	102
PHG4B481252X4	552	544	27	27	185	141	120	98
PHG4B601252X4	555	550	27	27	187	143	116	104

AIRFLOW PERFORMANCE - SIDE DUCT APPLICATION

Model	Motor Speed	External Static Pressure (in. W.C.)								
		0.1	0.2	0.3	0.4	0.5	0.6	0.7	0.8	1.0
		SCFM	SCFM	SCFM	SCFM	SCFM	SCFM	SCFM	SCFM	SCFM
PHG4A24075	Low (1)	590	550	490	440	390	350	290	230	80
	Medium Low (2)	860	830	790	740	690	640	590	550	460
	Medium (3)	950	910	880	840	800	740	690	650	570
	Medium High (4)	1120	1090	1050	1020	990	960	920	870	770
	High (5)	1200	1180	1140	1110	1080	1050	1010	980	880
PHG4A30075	Low (1)	720	680	630	580	520	470	430	380	270
	Medium Low (2)	930	890	850	820	770	710	650	610	530
	Medium (3)	1120	1090	1050	1020	990	960	920	870	770
	Medium High (4)	1200	1180	1140	1110	1080	1050	1010	980	880
	High (5)	1320	1290	1260	1240	1200	1170	1150	1110	1040
PHG4B36100	Low (1)	890	820	750	670	590	530	470	390	240
	Medium Low (2)	1190	1130	1080	1030	970	910	840	790	660
	Medium (3)	1330	1290	1240	1190	1140	1090	1030	980	850
	Medium High (4)	1520	1470	1430	1390	1340	1300	1250	1210	1090
	High (5)	1710	1670	1620	1590	1550	1510	1470	1420	1330
PHG4B42065	Low (1)	1010	950	890	820	760	690	620	550	420
	Medium Low (2)	1160	1100	1050	990	940	870	800	750	620
	Medium (3)	1480	1440	1390	1350	1300	1260	1210	1170	1050
	Medium High (4)	1620	1580	1540	1500	1460	1410	1370	1330	1230
	High (5)	1710	1670	1620	1590	1550	1510	1470	1420	1330
PHG4B42100	Low (1)	990	930	870	800	740	670	600	530	390
	Medium Low (2)	1320	1270	1230	1170	1130	1070	1020	960	840
	Medium (3)	1480	1440	1390	1350	1300	1260	1210	1170	1050
	Medium High (4)	1620	1580	1540	1500	1460	1410	1370	1330	1230
	High (5)	1710	1670	1620	1590	1550	1510	1470	1420	1330
PHG4B48100	Low (1)	1190	1140	1090	1030	970	910	850	790	680
	Medium Low (2)	1360	1310	1270	1220	1180	1130	1070	1010	900
	Medium (3)	1630	1590	1560	1520	1490	1440	1390	1350	1240
	Medium High (4)	1730	1690	1660	1620	1590	1540	1500	1450	1350
	High (5)	2010	1980	1940	1910	1870	1840	1810	1770	1640
PHG4B48125	Low (1)	1190	1140	1090	1030	970	910	850	790	680
	Medium Low (2)	1630	1590	1560	1520	1490	1440	1390	1350	1240
	Medium (3)	1730	1690	1660	1620	1590	1540	1500	1450	1350
	Medium High (4)	1860	1830	1790	1760	1720	1680	1640	1600	1520
	High (5)	2010	1980	1940	1910	1870	1840	1810	1770	1640
PHG4B60125	Low (1)	1340	1290	1240	1190	1140	1110	1050	1000	870
	Medium Low (2)	1750	1720	1680	1640	1610	1570	1530	1500	1420
	Medium (3)	1900	1870	1840	1800	1760	1730	1690	1650	1580
	Medium High (4)	2020	1990	1960	1920	1880	1850	1810	1770	1700
	High (5)	2240	2210	2180	2150	2100	2070	2040	2140	2050

Notes:

Airflow is tested with dry coil conditions, without air filters, at 230 V.

Applications above 0.8 in. W.C. external static pressure are not recommended.

Brushless DC high-efficiency standard ECM blower motor is used for all indoor blower assemblies.

Minimal variations in airflow performance data result from operating at 208 V. The data in the table can be used in those cases.

Heating applications are tested at 0.50 in. W.C. external static pressure. Cooling applications are tested per AHRI Standard 210/240.

The differences between side duct airflows and bottom duct airflows are insignificant.

ADDITIONAL STATIC RESISTANCE

Size (ton)	CFM	Wet Indoor Coil	Economizer ¹	Filter/Frame Kit
024 (2.0)	500	0.01	0.00	0.01
	600	0.01	0.00	0.02
	700	0.01	0.00	0.04
	800	0.02	0.01	0.06
	900	0.03	0.01	0.08
	1000	0.04	0.01	0.10
	1100	0.05	0.01	0.13
	1200	0.06	0.02	0.16
030 (2.5)	700	0.01	0.00	0.04
	800	0.02	0.01	0.06
	900	0.03	0.01	0.08
	1000	0.04	0.01	0.10
	1100	0.05	0.01	0.13
	1200	0.06	0.02	0.16
	1300	0.07	0.03	0.17
036 (3.0)	700	0.01	0.00	0.04
	800	0.02	0.01	0.06
	900	0.03	0.01	0.08
	1000	0.04	0.01	0.10
	1100	0.05	0.01	0.13
	1200	0.06	0.02	0.16
	1300	0.07	0.03	0.17
042 (3.5)	1100	0.02	0.02	0.04
	1200	0.03	0.02	0.04
	1300	0.04	0.02	0.05
	1400	0.05	0.03	0.05
	1500	0.06	0.04	0.06
	1600	0.07	0.04	0.07
	1700	0.07	0.04	0.08
	1800	0.08	0.04	0.09
	1900	0.09	0.05	0.10
	2000	0.09	0.05	0.11
	048 (4.0)	1100	0.02	0.02
1200		0.03	0.02	0.04
1300		0.04	0.02	0.05
1400		0.05	0.03	0.05
1500		0.06	0.04	0.06
1600		0.07	0.04	0.07
1700		0.07	0.04	0.08
1800		0.08	0.04	0.09
1900		0.09	0.05	0.10
2000		0.09	0.05	0.11
060 (5.0)	1100	0.02	0.02	0.04
	1200	0.03	0.02	0.04
	1300	0.04	0.02	0.05
	1400	0.05	0.03	0.05
	1500	0.06	0.04	0.06
	1600	0.07	0.04	0.07
	1700	0.07	0.04	0.08
	1800	0.08	0.04	0.09
	1900	0.09	0.05	0.10
	2000	0.09	0.05	0.11

1. The pressure drop through the economizer is greater for 100% outdoor air than for 100% return air. If the resistance of the return air duct is less than 0.25 IWG, the unit delivers less CFM during full economizer operation.

Note: Filter pressure drop is based on standard filter media tested at velocities not to exceed 300 ft/min.

BOTTOM DUCT DIMENSIONS (in.)

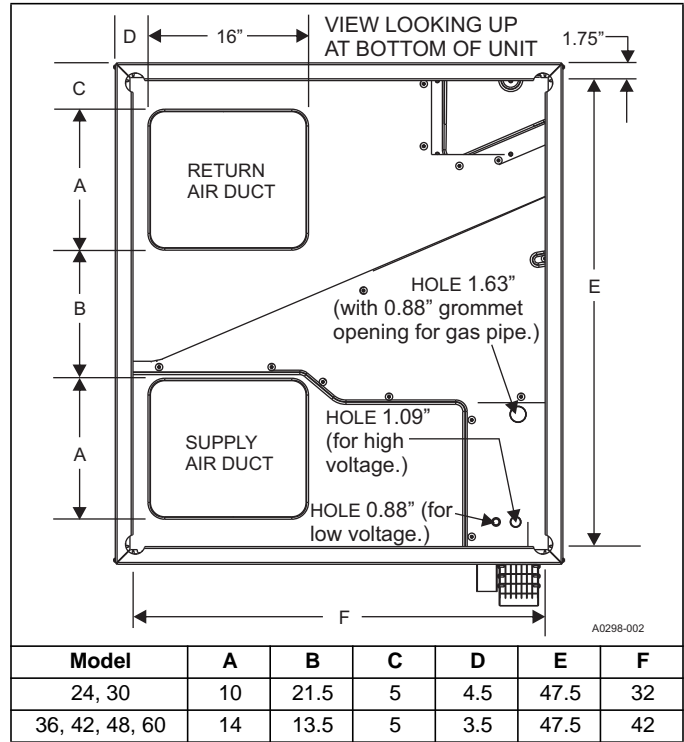

REAR DUCT DIMENSIONS (in.)

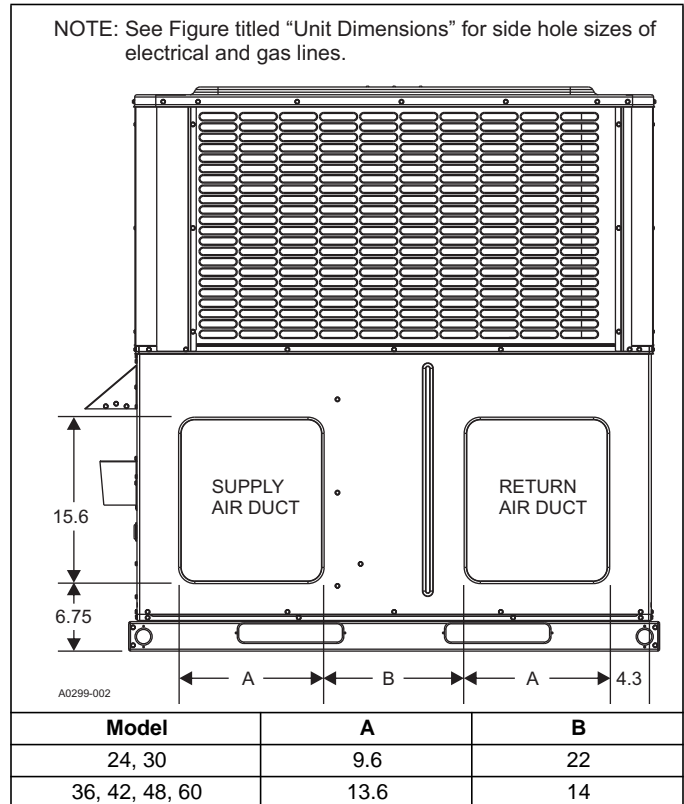

UNIT TYPICAL DUCT APPLICATIONS

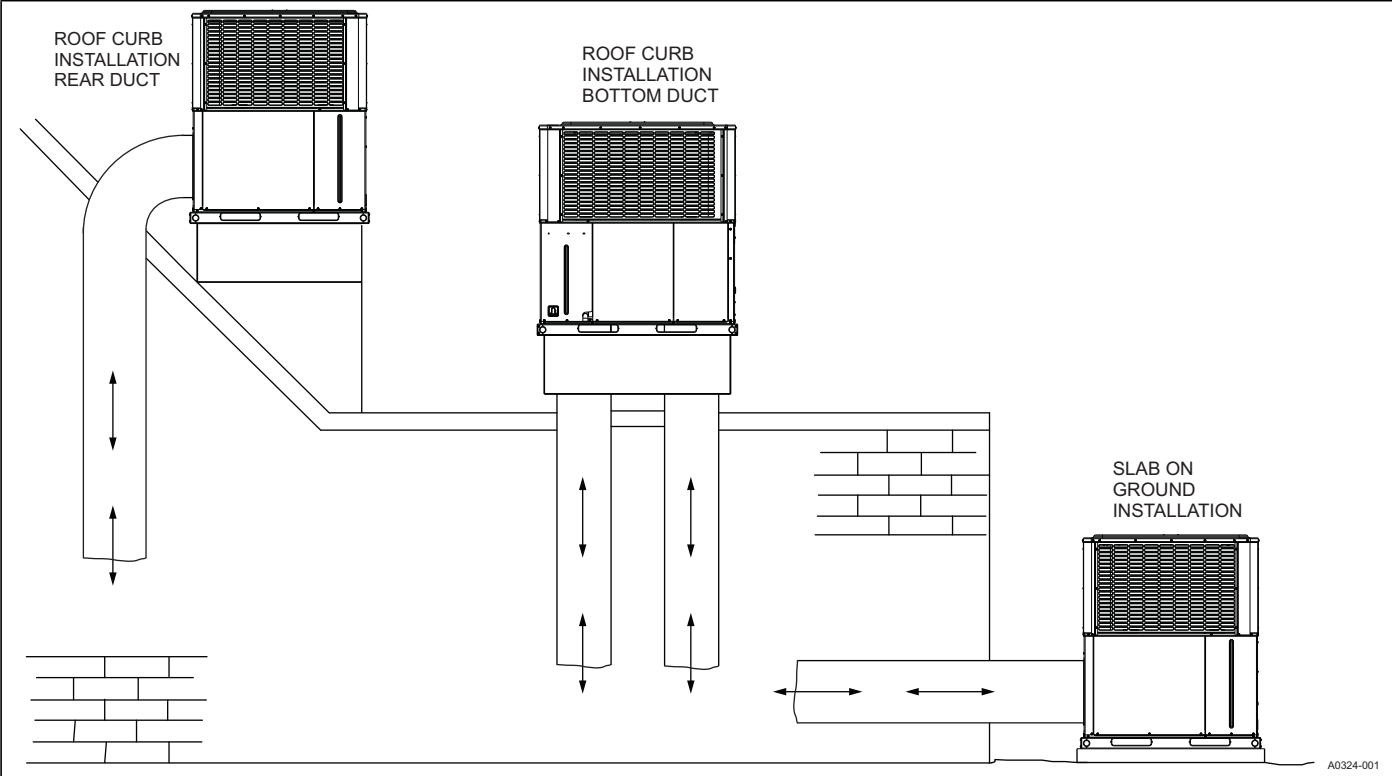

UNIT TYPICAL SLAB ON GROUND INSTALLATION

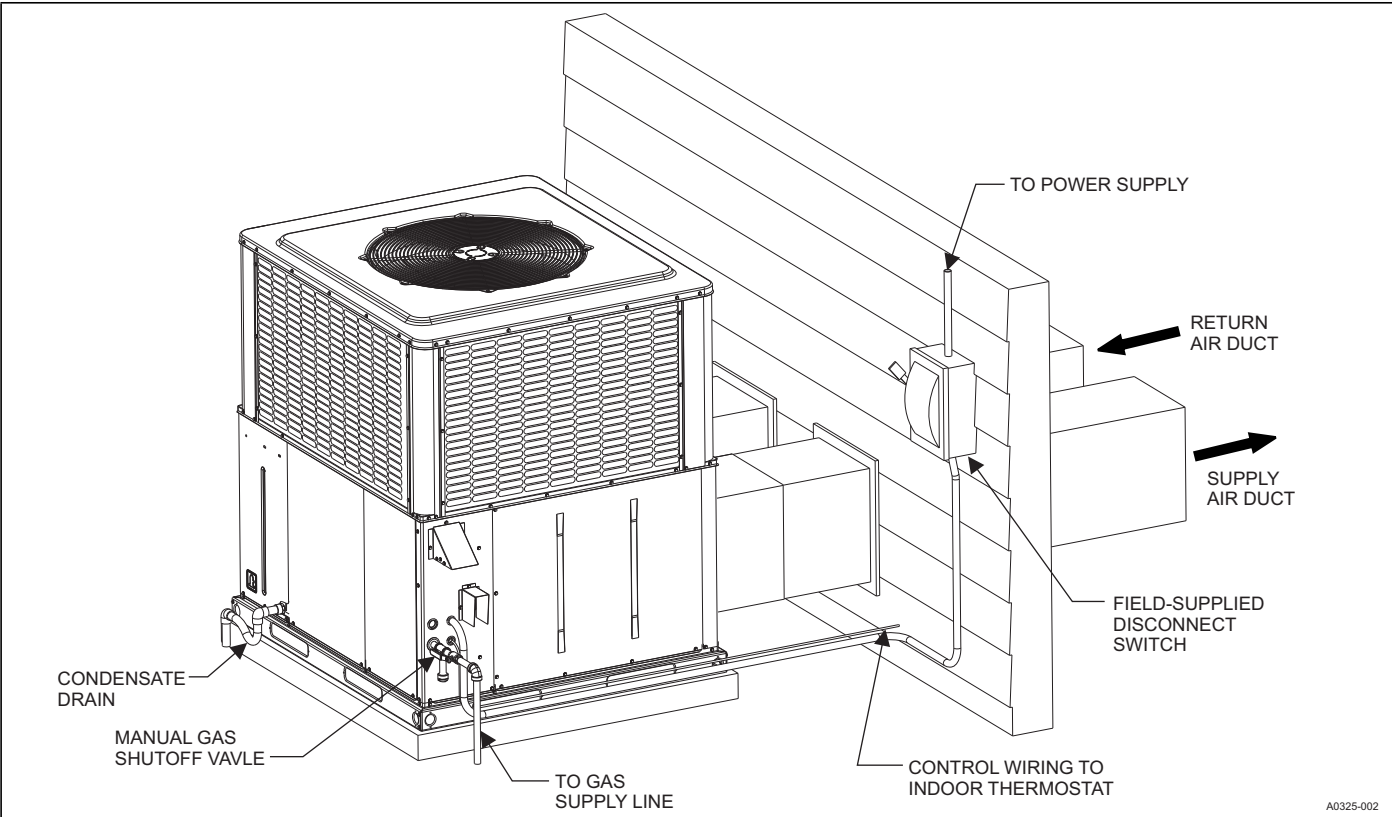

UNIT TYPICAL ROOF CURB INSTALLATION

